

---

# CHAPTER 5

---

## SYNCHRONOUS GENERATORS

**S***ynchronous generators or alternators* are synchronous machines used to convert mechanical power to ac electric power. This chapter explores the operation of synchronous generators, both when operating alone and when operating together with other generators.

### 5.1 SYNCHRONOUS GENERATOR CONSTRUCTION

In a synchronous generator, a dc current is applied to the rotor winding, which produces a rotor magnetic field. The rotor of the generator is then turned by a prime mover, producing a rotating magnetic field within the machine. This rotating magnetic field induces a three-phase set of voltages within the stator windings of the generator.

Two terms commonly used to describe the windings on a machine are *field windings* and *armature windings*. In general, the term “field windings” applies to the windings that produce the main magnetic field in a machine, and the term “armature windings” applies to the windings where the main voltage is induced. For synchronous machines, the field windings are on the rotor, so the terms “rotor windings” and “field windings” are used interchangeably. Similarly, the terms “stator windings” and “armature windings” are used interchangeably.

The rotor of a synchronous generator is essentially a large electromagnet. The magnetic poles on the rotor can be of either salient or nonsalient construction. The term *salient* means “protruding” or “sticking out,” and a *salient pole* is a magnetic pole that sticks out from the surface of the rotor. On the other hand, a

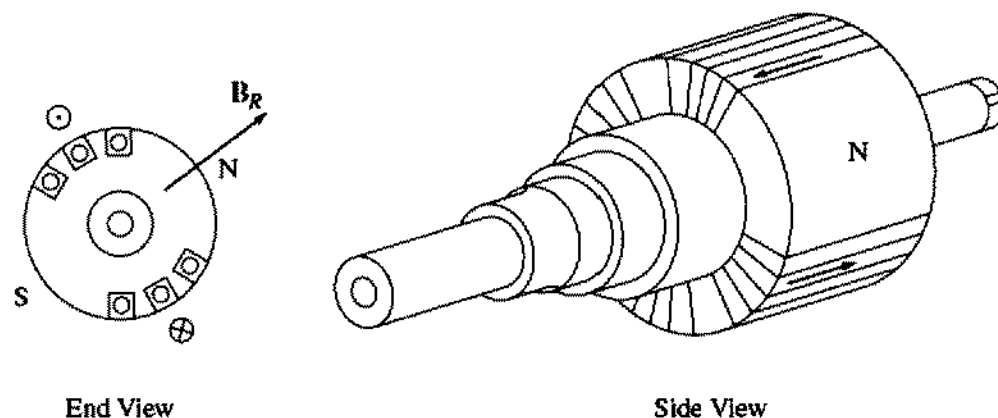

**FIGURE 5-1**  
A nonsalient two-pole rotor for a synchronous machine.

*nonsalient pole* is a magnetic pole constructed flush with the surface of the rotor. A nonsalient-pole rotor is shown in Figure 5-1, while a salient-pole rotor is shown in Figure 5-2. Nonsalient-pole rotors are normally used for two- and four-pole rotors, while salient-pole rotors are normally used for rotors with four or more poles. Because the rotor is subjected to changing magnetic fields, it is constructed of thin laminations to reduce eddy current losses.

A dc current must be supplied to the field circuit on the rotor. Since the rotor is rotating, a special arrangement is required to get the dc power to its field windings. There are two common approaches to supplying this dc power:

1. Supply the dc power from an external dc source to the rotor by means of *slip rings* and *brushes*.
2. Supply the dc power from a special dc power source mounted directly on the shaft of the synchronous generator.

Slip rings are metal rings completely encircling the shaft of a machine but insulated from it. One end of the dc rotor winding is tied to each of the two slip rings on the shaft of the synchronous machine, and a stationary brush rides on each slip ring. A “brush” is a block of graphitelike carbon compound that conducts electricity freely but has very low friction, so that it doesn’t wear down the slip ring. If the positive end of a dc voltage source is connected to one brush and the negative end is connected to the other, then the same dc voltage will be applied to the field winding at all times regardless of the angular position or speed of the rotor.

Slip rings and brushes create a few problems when they are used to supply dc power to the field windings of a synchronous machine. They increase the amount of maintenance required on the machine, since the brushes must be checked for wear regularly. In addition, brush voltage drop can be the cause of significant power losses on machines with larger field currents. Despite these problems, slip rings and brushes are used on all smaller synchronous machines, because no other method of supplying the dc field current is cost-effective.

On larger generators and motors, *brushless exciters* are used to supply the dc field current to the machine. A brushless exciter is a small ac generator with its

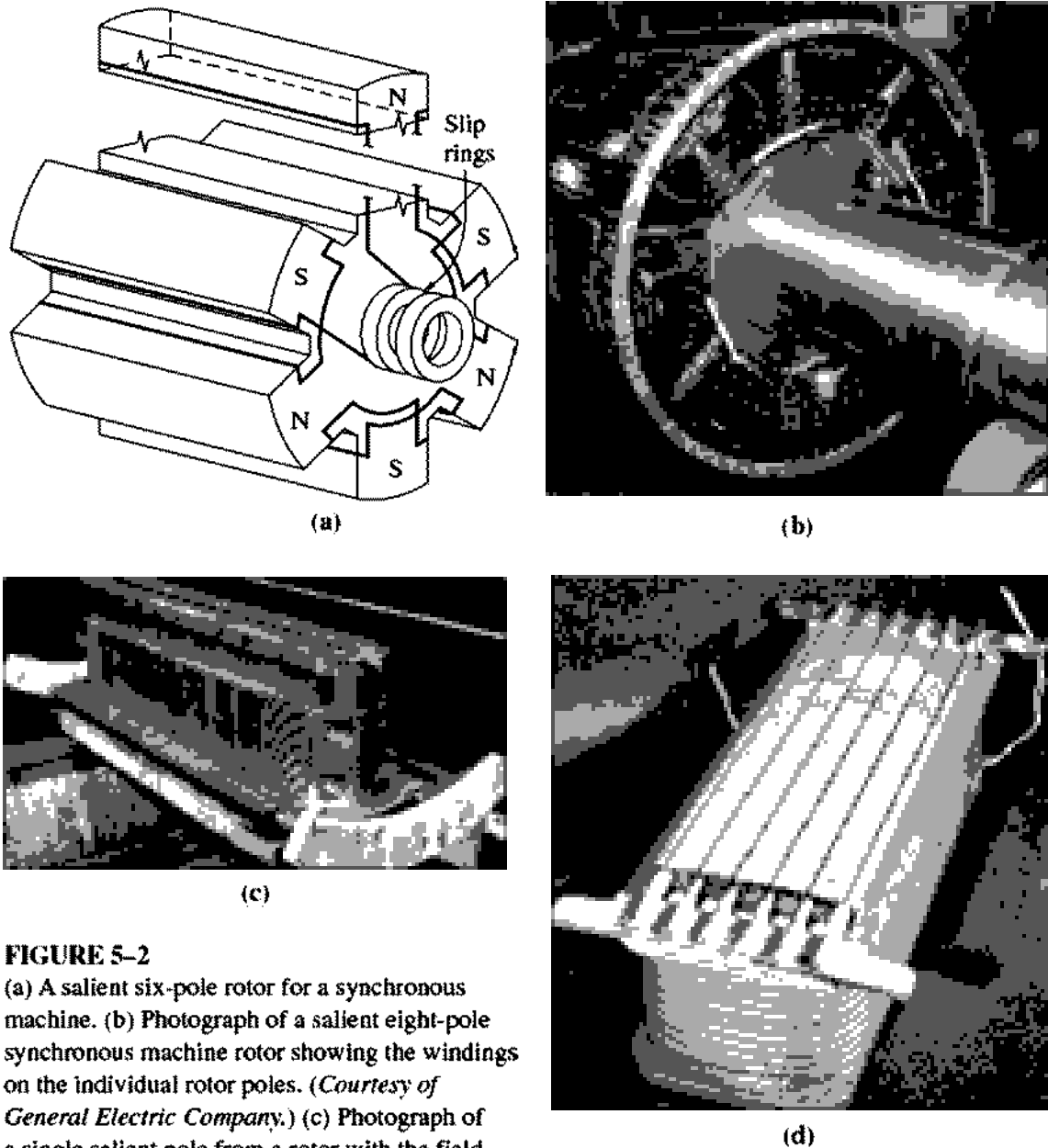

**FIGURE 5-2**

(a) A salient six-pole rotor for a synchronous machine. (b) Photograph of a salient eight-pole synchronous machine rotor showing the windings on the individual rotor poles. (Courtesy of General Electric Company.) (c) Photograph of a single salient pole from a rotor with the field windings not yet in place. (Courtesy of General Electric Company.) (d) A single salient pole shown after the field windings are installed but before it is mounted on the rotor. (Courtesy of Westinghouse Electric Company.)

field circuit mounted on the stator and its armature circuit mounted on the rotor shaft. The three-phase output of the exciter generator is rectified to direct current by a three-phase rectifier circuit also mounted on the shaft of the generator, and is then fed into the main dc field circuit. By controlling the small dc field current of the exciter generator (located on the stator), it is possible to adjust the field current on the main machine *without slip rings and brushes*. This arrangement is shown schematically in Figure 5-3, and a synchronous machine rotor with a brushless exciter mounted on the same shaft is shown in Figure 5-4. Since no mechanical contacts ever occur between the rotor and the stator, a brushless exciter requires much less maintenance than slip rings and brushes.

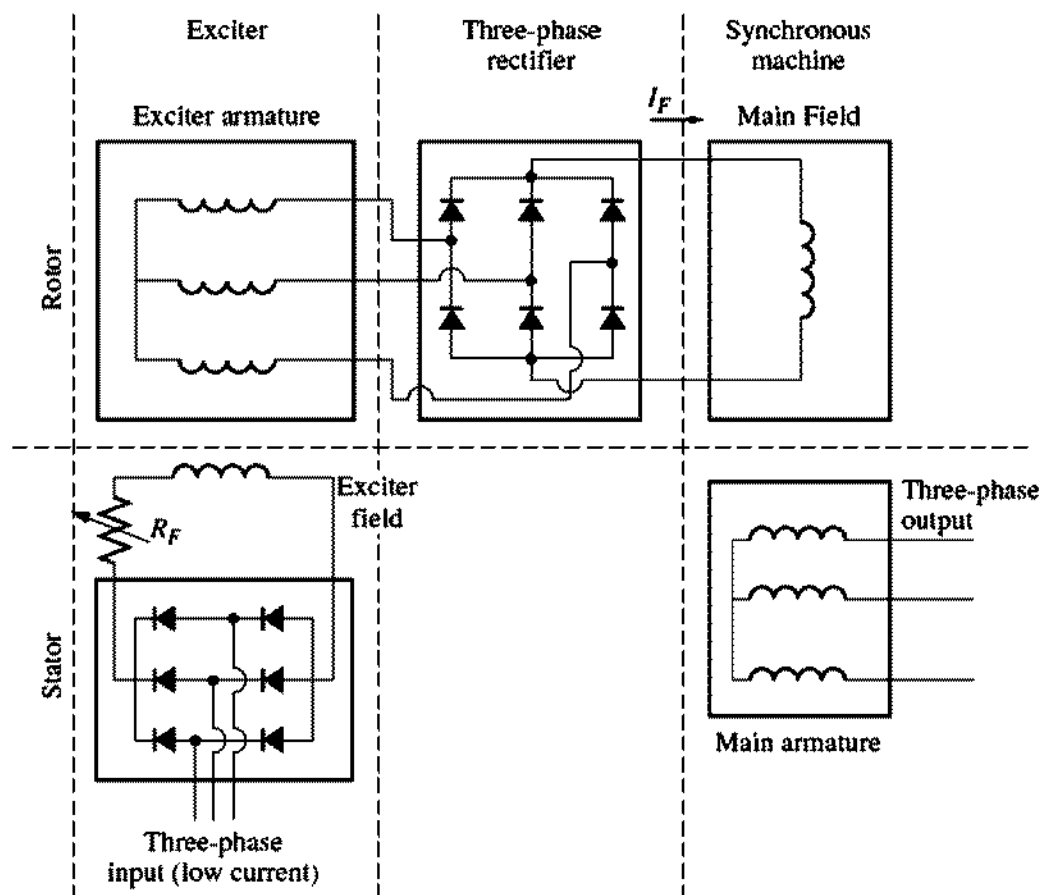

**FIGURE 5-3**

A brushless exciter circuit. A small three-phase current is rectified and used to supply the field circuit of the exciter, which is located on the stator. The output of the armature circuit of the exciter (on the rotor) is then rectified and used to supply the field current of the main machine.

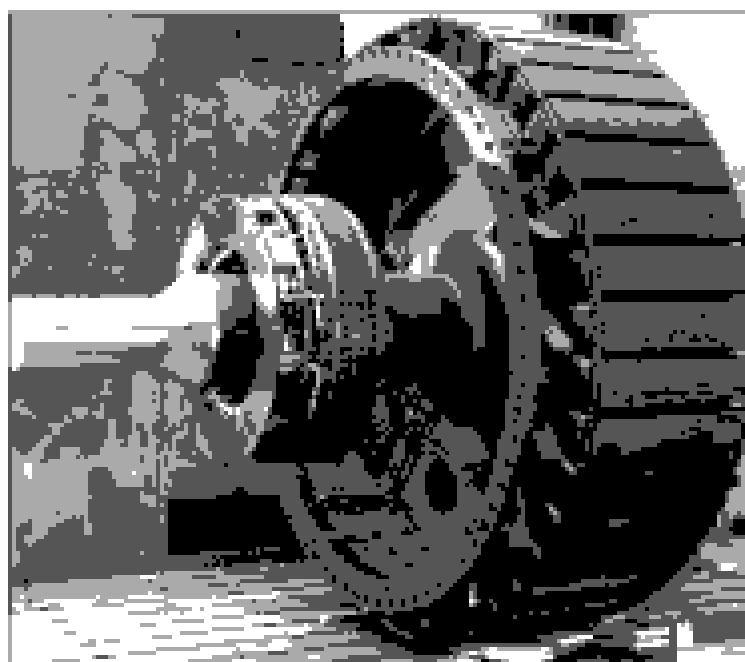

**FIGURE 5-4**

Photograph of a synchronous machine rotor with a brushless exciter mounted on the same shaft. Notice the rectifying electronics visible next to the armature of the exciter. (Courtesy of Westinghouse Electric Company.)

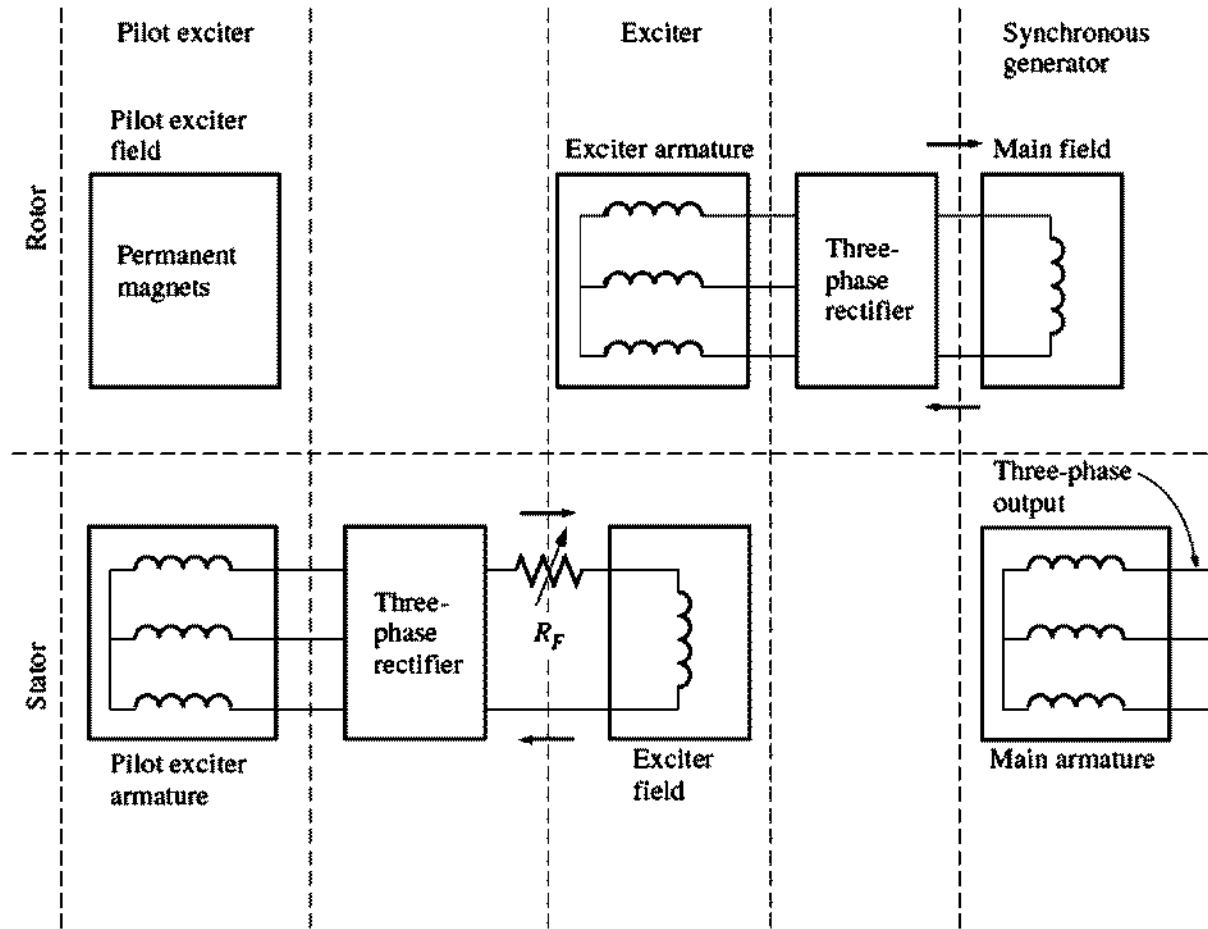
**FIGURE 5-5**

A brushless excitation scheme that includes a pilot exciter. The permanent magnets of the pilot exciter produce the field current of the exciter, which in turn produces the field current of the main machine.

To make the excitation of a generator *completely* independent of any external power sources, a small pilot exciter is often included in the system. A *pilot exciter* is a small ac generator with *permanent magnets* mounted on the rotor shaft and a three-phase winding on the stator. It produces the power for the field circuit of the exciter, which in turn controls the field circuit of the main machine. If a pilot exciter is included on the generator shaft, then *no external electric power* is required to run the generator (see Figure 5-5).

Many synchronous generators that include brushless exciters also have slip rings and brushes, so that an auxiliary source of dc field current is available in emergencies.

The stator of a synchronous generator has already been described in Chapter 4, and more details of stator construction are found in Appendix B. Synchronous generator stators are normally made of preformed stator coils in a double-layer winding. The winding itself is distributed and chorded in order to reduce the harmonic content of the output voltages and currents, as described in Appendix B.

A cutaway diagram of a complete large synchronous machine is shown in Figure 5-6. This drawing shows an eight-pole salient-pole rotor, a stator with distributed double-layer windings, and a brushless exciter.

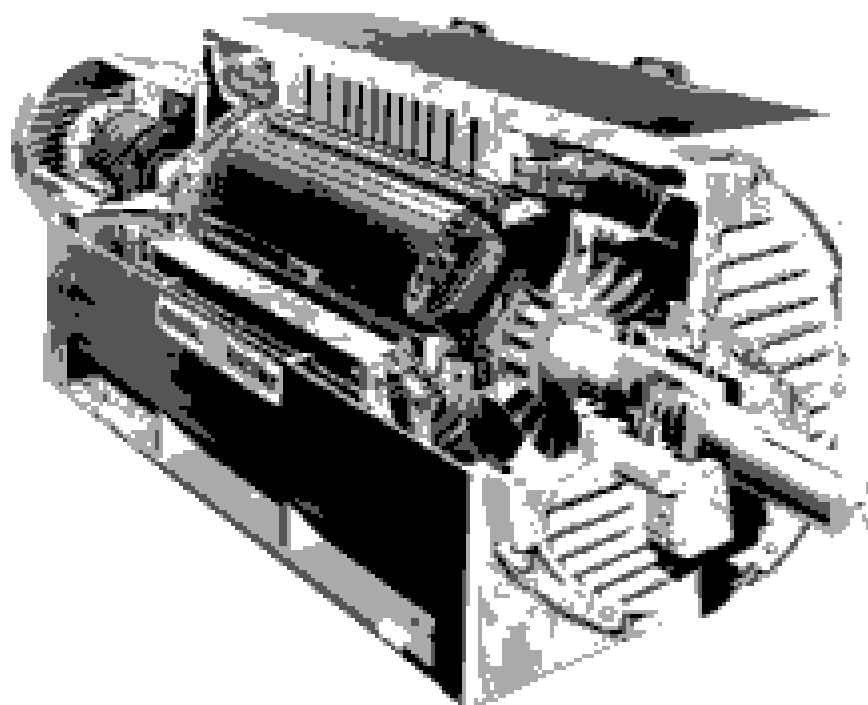

FIGURE 5-6

A cutaway diagram of a large synchronous machine. Note the salient-pole construction and the on-shaft exciter. (Courtesy of General Electric Company.)

## 5.2 THE SPEED OF ROTATION OF A SYNCHRONOUS GENERATOR

Synchronous generators are by definition *synchronous*, meaning that the electrical frequency produced is locked in or synchronized with the mechanical rate of rotation of the generator. A synchronous generator's rotor consists of an electromagnet to which direct current is supplied. The rotor's magnetic field points in whatever direction the rotor is turned. Now, the rate of rotation of the magnetic fields in the machine is related to the stator electrical frequency by Equation (4-34):

$$f_e = \frac{n_m P}{120} \quad (4-34)$$

where  $f_e$  = electrical frequency, in Hz  
 $n_m$  = mechanical speed of magnetic field, in r/min (equals speed of rotor for synchronous machines)  
 $P$  = number of poles

Since the rotor turns at the same speed as the magnetic field, *this equation relates the speed of rotor rotation to the resulting electrical frequency*. Electric power is generated at 50 or 60 Hz, so the generator must turn at a fixed speed depending on the number of poles on the machine. For example, to generate 60-Hz power in a two-pole machine, the rotor *must* turn at 3600 r/min. To generate 50-Hz power in a four-pole machine, the rotor *must* turn at 1500 r/min. The required rate of rotation for a given frequency can always be calculated from Equation (4-34).

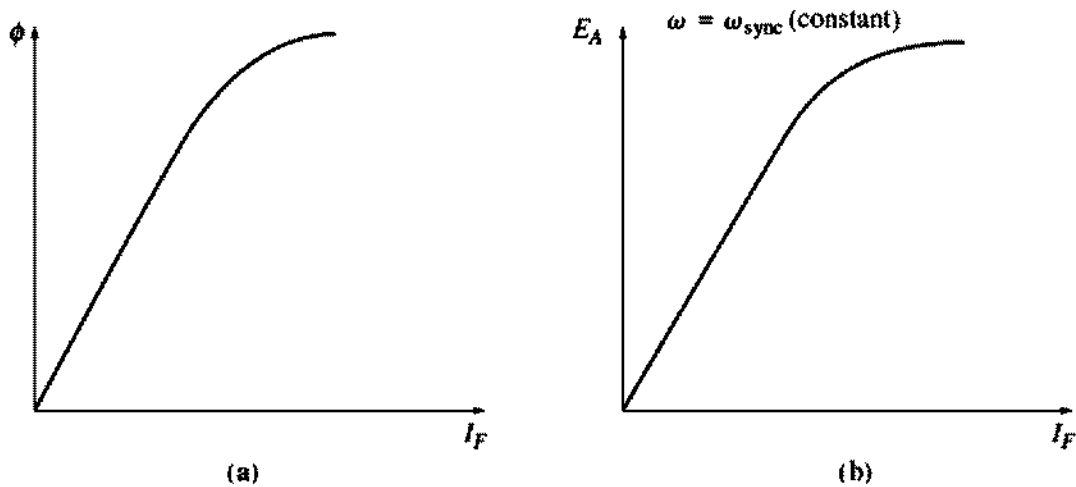
**FIGURE 5-7**

(a) Plot of flux versus field current for a synchronous generator. (b) The magnetization curve for the synchronous generator.

### 5.3 THE INTERNAL GENERATED VOLTAGE OF A SYNCHRONOUS GENERATOR

In Chapter 4, the magnitude of the voltage induced in a given stator phase was found to be

$$E_A = \sqrt{2}\pi N_C \phi f \quad (4-50)$$

This voltage depends on the flux  $\phi$  in the machine, the frequency or speed of rotation, and the machine's construction. In solving problems with synchronous machines, this equation is sometimes rewritten in a simpler form that emphasizes the quantities that are variable during machine operation. This simpler form is

$$E_A = K\phi\omega \quad (5-1)$$

where  $K$  is a constant representing the construction of the machine. If  $\omega$  is expressed in *electrical* radians per second, then

$$K = \frac{N_c}{\sqrt{2}} \quad (5-2)$$

while if  $\omega$  is expressed in *mechanical* radians per second, then

$$K = \frac{N_c P}{\sqrt{2}} \quad (5-3)$$

The internal generated voltage  $E_A$  is directly proportional to the flux and to the speed, but the flux itself depends on the current flowing in the rotor field circuit. The field current  $I_F$  is related to the flux  $\phi$  in the manner shown in Figure 5-7a. Since  $E_A$  is directly proportional to the flux, the internal generated voltage  $E_A$  is related to the field current as shown in Figure 5-7b. This plot is called the *magnetization curve* or the *open-circuit characteristic* of the machine.

## 5.4 THE EQUIVALENT CIRCUIT OF A SYNCHRONOUS GENERATOR

The voltage  $E_A$  is the internal generated voltage produced in one phase of a synchronous generator. However, this voltage  $E_A$  is *not* usually the voltage that appears at the terminals of the generator. In fact, the only time the internal voltage  $E_A$  is the same as the output voltage  $V_\phi$  of a phase is when there is no armature current flowing in the machine. Why is the output voltage  $V_\phi$  from a phase not equal to  $E_A$ , and what is the relationship between the two voltages? The answer to these questions yields the model of a synchronous generator.

There are a number of factors that cause the difference between  $E_A$  and  $V_\phi$ :

1. The distortion of the air-gap magnetic field by the current flowing in the stator, called *armature reaction*.
2. The self-inductance of the armature coils.
3. The resistance of the armature coils.
4. The effect of salient-pole rotor shapes.

We will explore the effects of the first three factors and derive a machine model from them. In this chapter, the effects of a salient-pole shape on the operation of a synchronous machine will be ignored; in other words, all the machines in this chapter are assumed to have nonsalient or cylindrical rotors. Making this assumption will cause the calculated answers to be slightly inaccurate if a machine does indeed have salient-pole rotors, but the errors are relatively minor. A discussion of the effects of rotor pole saliency is included in Appendix C.

The first effect mentioned, and normally the largest one, is armature reaction. When a synchronous generator's rotor is spun, a voltage  $E_A$  is induced in the generator's stator windings. If a load is attached to the terminals of the generator, a current flows. But a three-phase stator current flow will produce a magnetic field of its own in the machine. This *stator* magnetic field distorts the original rotor magnetic field, changing the resulting phase voltage. This effect is called *armature reaction* because the armature (stator) current affects the magnetic field which produced it in the first place.

To understand armature reaction, refer to Figure 5–8. Figure 5–8a shows a two-pole rotor spinning inside a three-phase stator. There is no load connected to the stator. The rotor magnetic field  $B_R$  produces an internal generated voltage  $E_A$  whose peak value coincides with the direction of  $B_R$ . As was shown in the last chapter, the voltage will be positive out of the conductors at the top and negative into the conductors at the bottom of the figure. With no load on the generator, there is no armature current flow, and  $E_A$  will be equal to the phase voltage  $V_\phi$ .

Now suppose that the generator is connected to a lagging load. Because the load is lagging, the peak current will occur at an angle *behind* the peak voltage. This effect is shown in Figure 5–8b.

The current flowing in the stator windings produces a magnetic field of its own. This stator magnetic field is called  $B_S$  and its direction is given by the right-

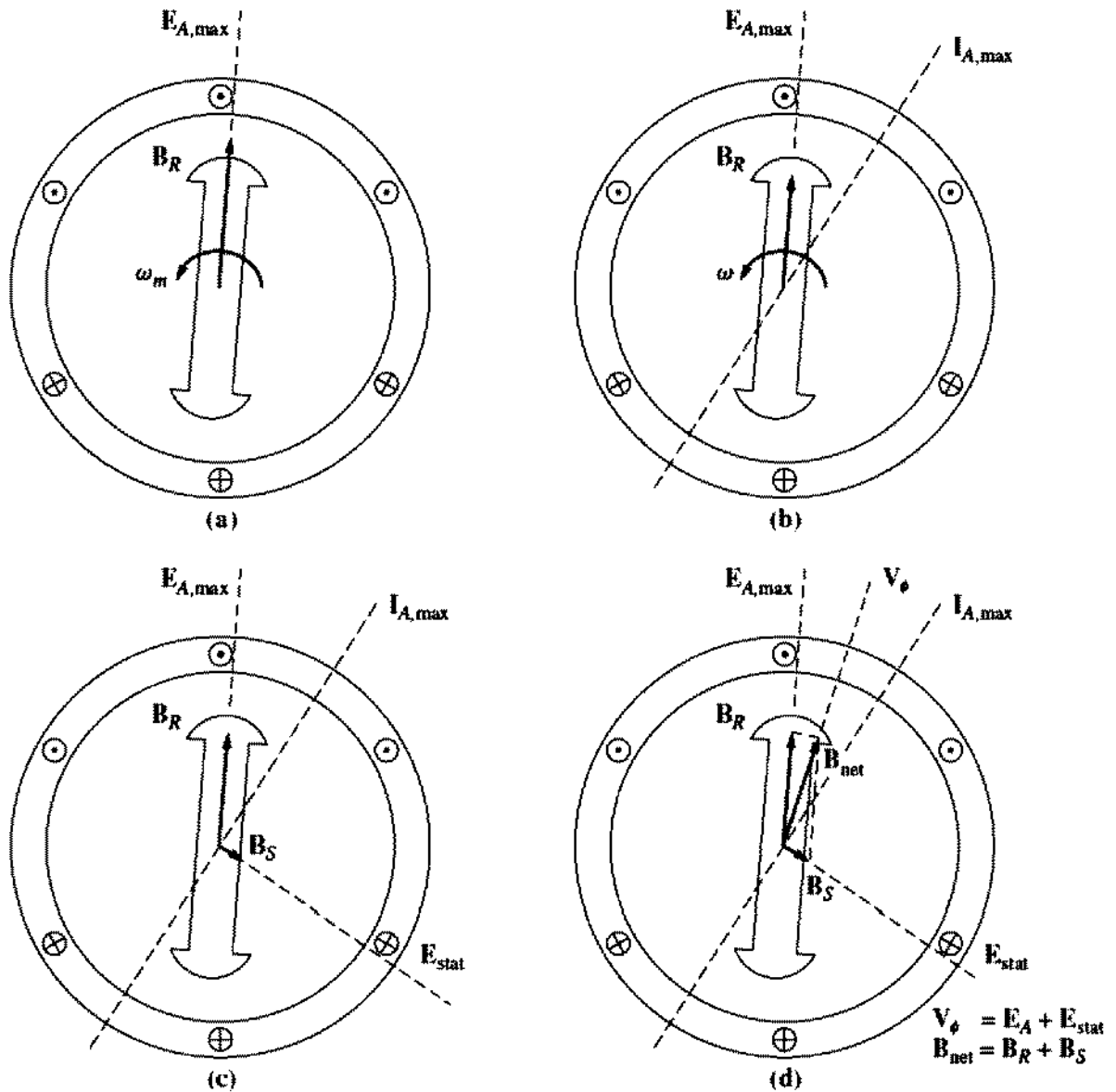

**FIGURE 5-8**

The development of a model for armature reaction: (a) A rotating magnetic field produces the internal generated voltage  $E_A$ . (b) The resulting voltage produces a lagging current flow when connected to a lagging load. (c) The stator current produces its own magnetic field  $B_S$ , which produces its own voltage  $E_{stat}$  in the stator windings of the machine. (d) The field  $B_S$  adds to  $B_R$ , distorting it into  $B_{net}$ . The voltage  $E_{stat}$  adds to  $E_A$ , producing  $V_\phi$  at the output of the phase.

hand rule to be as shown in Figure 5-8c. The stator magnetic field  $B_S$  produces a voltage of its own in the stator, and this voltage is called  $E_{stat}$  on the figure.

With two voltages present in the stator windings, the total voltage in a phase is just the *sum* of the internal generated voltage  $E_A$  and the armature reaction voltage  $E_{stat}$ :

$$V_\phi = E_A + E_{stat} \quad (5-4)$$

The net magnetic field  $B_{net}$  is just the sum of the rotor and stator magnetic fields:

$$B_{net} = B_R + B_S \quad (5-5)$$

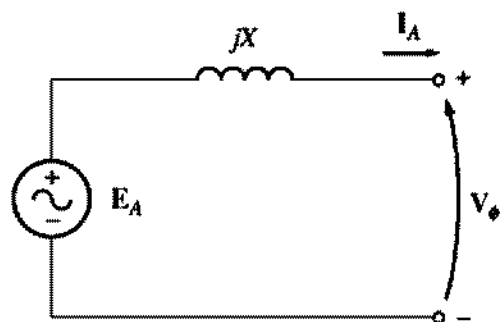

FIGURE 5-9  
A simple circuit (see text).

Since the angles of  $\mathbf{E}_A$  and  $\mathbf{B}_R$  are the same and the angles of  $\mathbf{E}_{\text{stat}}$  and  $\mathbf{B}_S$  are the same, the resulting magnetic field  $\mathbf{B}_{\text{net}}$  will coincide with the net voltage  $\mathbf{V}_\phi$ . The resulting voltages and currents are shown in Figure 5-8d.

How can the effects of armature reaction on the phase voltage be modeled? First, note that the voltage  $\mathbf{E}_{\text{stat}}$  lies at an angle of  $90^\circ$  behind the plane of maximum current  $\mathbf{I}_A$ . Second, the voltage  $\mathbf{E}_{\text{stat}}$  is directly proportional to the current  $\mathbf{I}_A$ . If  $X$  is a constant of proportionality, then *the armature reaction voltage can be expressed as*

$$\mathbf{E}_{\text{stat}} = -jX\mathbf{I}_A \quad (5-6)$$

The voltage on a phase is thus

$$\boxed{\mathbf{V}_\phi = \mathbf{E}_A - jX\mathbf{I}_A} \quad (5-7)$$

Look at the circuit shown in Figure 5-9. The Kirchhoff's voltage law equation for this circuit is

$$\mathbf{V}_\phi = \mathbf{E}_A - jX\mathbf{I}_A \quad (5-8)$$

This is exactly the same equation as the one describing the armature reaction voltage. Therefore, the armature reaction voltage can be modeled as an inductor in series with the internal generated voltage.

In addition to the effects of armature reaction, the stator coils have a self-inductance and a resistance. If the stator self-inductance is called  $L_A$  (and its corresponding reactance is called  $X_A$ ) while the stator resistance is called  $R_A$ , then the total difference between  $\mathbf{E}_A$  and  $\mathbf{V}_\phi$  is given by

$$\mathbf{V}_\phi = \mathbf{E}_A - jX\mathbf{I}_A - jX_A\mathbf{I}_A - R_A\mathbf{I}_A \quad (5-9)$$

The armature reaction effects and the self-inductance in the machine are both represented by reactances, and it is customary to combine them into a single reactance, called the *synchronous reactance* of the machine:

$$X_S = X + X_A \quad (5-10)$$

Therefore, the final equation describing  $\mathbf{V}_\phi$  is

$$\boxed{\mathbf{V}_\phi = \mathbf{E}_A - jX_S\mathbf{I}_A - R_A\mathbf{I}_A} \quad (5-11)$$

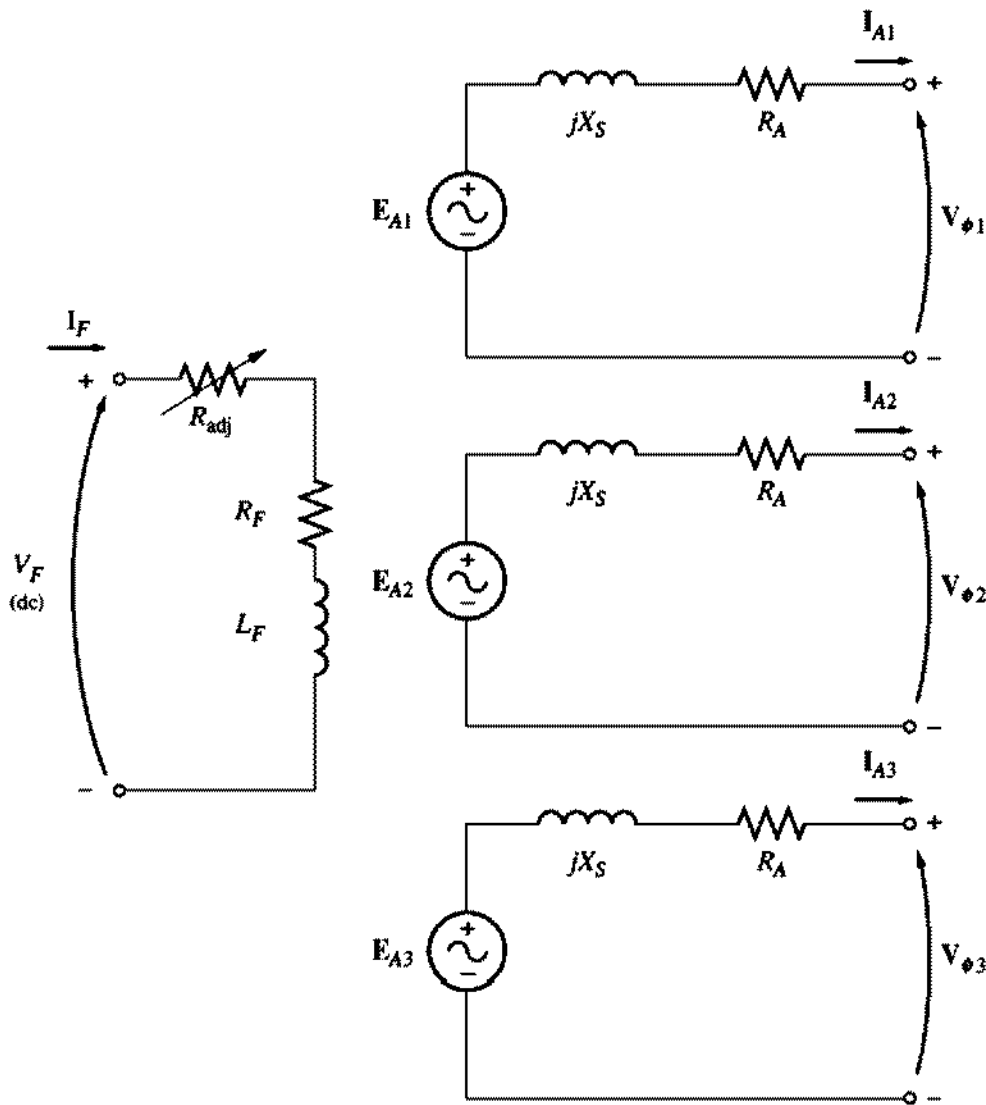
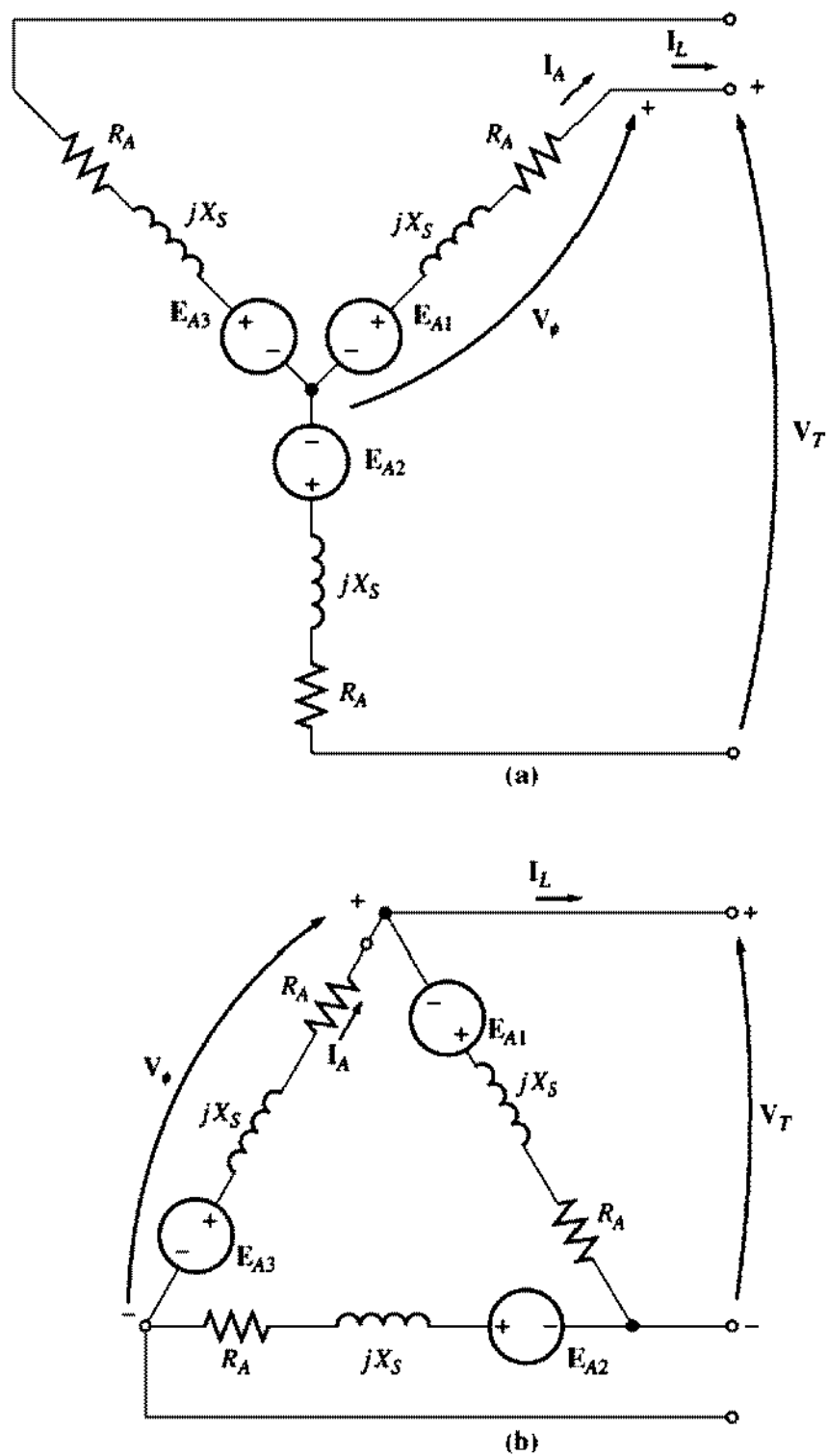

**FIGURE 5-10**

The full equivalent circuit of a three-phase synchronous generator.

It is now possible to sketch the equivalent circuit of a three-phase synchronous generator. The full equivalent circuit of such a generator is shown in Figure 5-10. This figure shows a dc power source supplying the rotor field circuit, which is modeled by the coil's inductance and resistance in series. In series with  $R_F$  is an adjustable resistor  $R_{adj}$  which controls the flow of field current. The rest of the equivalent circuit consists of the models for each phase. Each phase has an internal generated voltage with a series inductance  $X_S$  (consisting of the sum of the armature reactance and the coil's self-inductance) and a series resistance  $R_A$ . The voltages and currents of the three phases are  $120^\circ$  apart in angle, but otherwise the three phases are identical.

These three phases can be either Y- or  $\Delta$ -connected as shown in Figure 5-11. If they are Y-connected, then the terminal voltage  $V_T$  is related to the phase voltage by

$$V_T = \sqrt{3}V_\phi \quad (5-12)$$

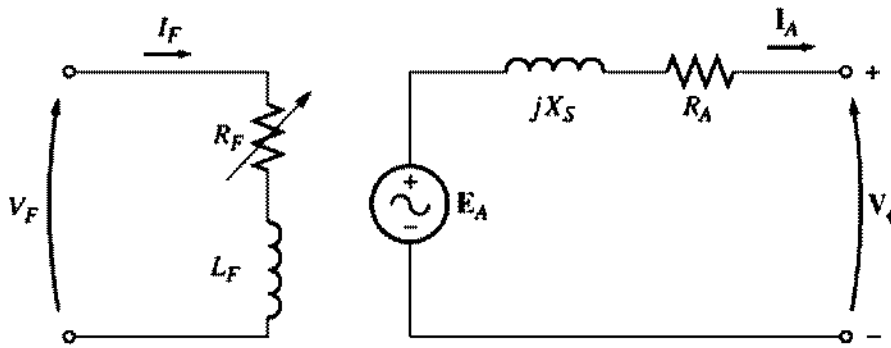

**FIGURE 5-11**  
The generator equivalent circuit connected in (a) Y and (b)  $\Delta$ .

If they are  $\Delta$ -connected, then

$$V_T = V_\phi \tag{5-13}$$

The fact that the three phases of a synchronous generator are identical in all respects except for phase angle normally leads to the use of a *per-phase equivalent circuit*. The per-phase equivalent circuit of this machine is shown in Fig-

**FIGURE 5-12**

The per-phase equivalent circuit of a synchronous generator. The internal field circuit resistance and the external variable resistance have been combined into a single resistor  $R_F$ .

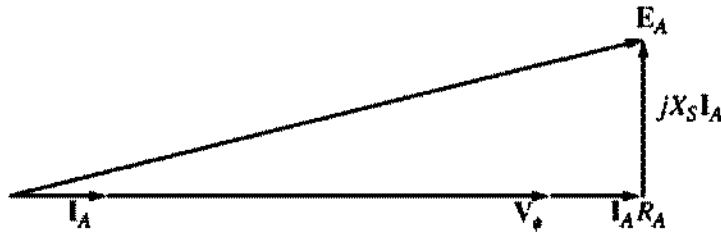
**FIGURE 5-13**

The phasor diagram of a synchronous generator at unity power factor.

ure 5-12. One important fact must be kept in mind when the per-phase equivalent circuit is used: The three phases have the same voltages and currents *only* when the loads attached to them are *balanced*. If the generator's loads are not balanced, more sophisticated techniques of analysis are required. These techniques are beyond the scope of this book.

## 5.5 THE PHASOR DIAGRAM OF A SYNCHRONOUS GENERATOR

Because the voltages in a synchronous generator are ac voltages, they are usually expressed as phasors. Since phasors have both a magnitude and an angle, the relationship between them must be expressed by a two-dimensional plot. When the voltages within a phase ( $E_A$ ,  $V_\phi$ ,  $jX_S I_A$ , and  $R_A I_A$ ) and the current  $I_A$  in the phase are plotted in such a fashion as to show the relationships among them, the resulting plot is called a *phasor diagram*.

For example, Figure 5-13 shows these relationships when the generator is supplying a load at unity power factor (a purely resistive load). From Equation (5-11), the total voltage  $E_A$  differs from the terminal voltage of the phase  $V_\phi$  by the resistive and inductive voltage drops. All voltages and currents are referenced to  $V_\phi$ , which is arbitrarily assumed to be at an angle of  $0^\circ$ .

This phasor diagram can be compared to the phasor diagrams of generators operating at lagging and leading power factors. These phasor diagrams are shown

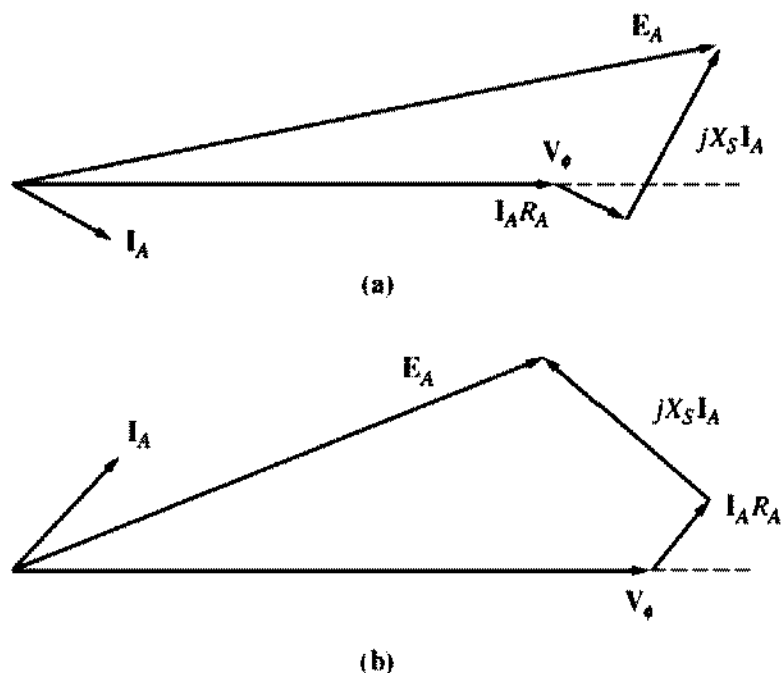

FIGURE 5-14

The phasor diagram of a synchronous generator at (a) lagging and (b) leading power factor.

in Figure 5-14. Notice that, for a given phase voltage and armature current, a larger internal generated voltage  $E_A$  is needed for lagging loads than for leading loads. Therefore, a larger field current is needed with lagging loads to get the same terminal voltage, because

$$E_A = K\phi\omega \quad (5-1)$$

and  $\omega$  must be constant to keep a constant frequency.

Alternatively, for a given field current and magnitude of load current, the terminal voltage is lower for lagging loads and higher for leading loads.

In real synchronous machines, the synchronous reactance is normally much larger than the winding resistance  $R_A$ , so  $R_A$  is often neglected in the *qualitative* study of voltage variations. For accurate numerical results,  $R_A$  must of course be considered.

## 5.6 POWER AND TORQUE IN SYNCHRONOUS GENERATORS

A synchronous generator is a synchronous machine used as a generator. It converts mechanical power to three-phase electrical power. The source of mechanical power, the *prime mover*, may be a diesel engine, a steam turbine, a water turbine, or any similar device. Whatever the source, it must have the basic property that its speed is almost constant regardless of the power demand. If that were not so, then the resulting power system's frequency would wander.

Not all the mechanical power going into a synchronous generator becomes electrical power out of the machine. The difference between input power and output power represents the losses of the machine. A power-flow diagram for a synchro-

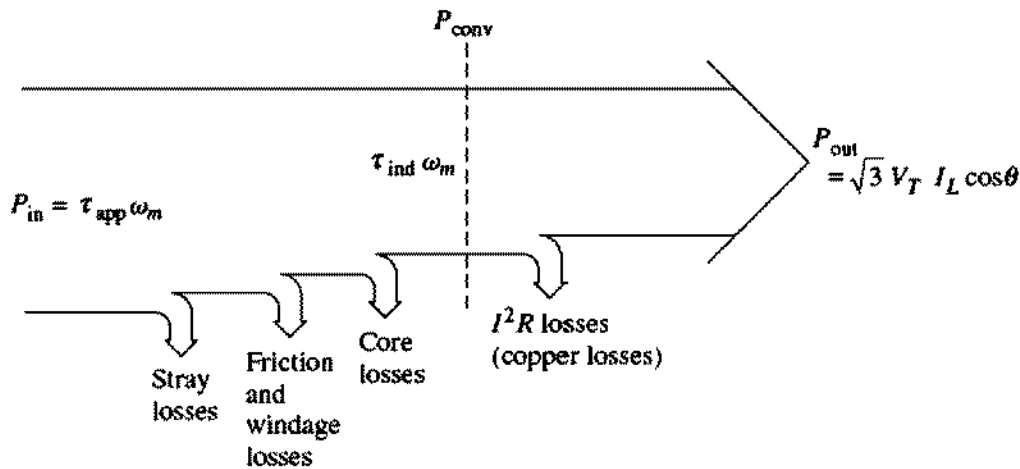

**FIGURE 5-15**  
The power-flow diagram of a synchronous generator.

nous generator is shown in Figure 5-15. The input mechanical power is the shaft power in the generator  $P_{in} = \tau_{app} \omega_m$ , while the power converted from mechanical to electrical form internally is given by

$$P_{conv} = \tau_{ind} \omega_m \quad (5-14)$$

$$= 3E_A I_A \cos \gamma \quad (5-15)$$

where  $\gamma$  is the angle between  $E_A$  and  $I_A$ . The difference between the input power to the generator and the power converted in the generator represents the mechanical, core, and stray losses of the machine.

The real electrical output power of the synchronous generator can be expressed in line quantities as

$$P_{out} = \sqrt{3} V_T I_L \cos \theta \quad (5-16)$$

and in phase quantities as

$$P_{out} = 3V_\phi I_A \cos \theta \quad (5-17)$$

The reactive power output can be expressed in line quantities as

$$Q_{out} = \sqrt{3} V_T I_L \sin \theta \quad (5-18)$$

or in phase quantities as

$$Q_{out} = 3V_\phi I_A \sin \theta \quad (5-19)$$

If the armature resistance  $R_A$  is ignored (since  $X_S \gg R_A$ ), then a very useful equation can be derived to approximate the output power of the generator. To derive this equation, examine the phasor diagram in Figure 5-16. Figure 5-16 shows a simplified phasor diagram of a generator with the stator resistance ignored. Notice that the vertical segment  $bc$  can be expressed as either  $E_A \sin \delta$  or  $X_S I_A \cos \theta$ . Therefore,

$$I_A \cos \theta = \frac{E_A \sin \delta}{X_S}$$

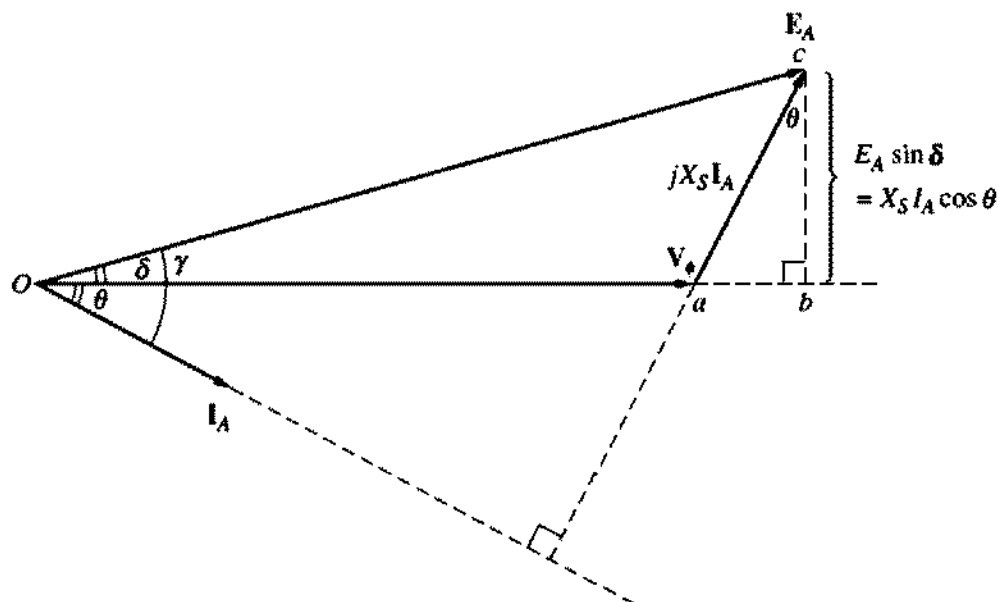

**FIGURE 5-16**  
Simplified phasor diagram with armature resistance ignored.

and substituting this expression into Equation (5-17) gives

$$P = \frac{3V_\phi E_A \sin \delta}{X_S} \quad (5-20)$$

Since the resistances are assumed to be zero in Equation (5-20), there are no electrical losses in this generator, and this equation is both  $P_{\text{conv}}$  and  $P_{\text{out}}$ .

Equation (5-20) shows that the power produced by a synchronous generator depends on the angle  $\delta$  between  $V_\phi$  and  $E_A$ . The angle  $\delta$  is known as the *torque angle* of the machine. Notice also that the maximum power that the generator can supply occurs when  $\delta = 90^\circ$ . At  $\delta = 90^\circ$ ,  $\sin \delta = 1$ , and

$$P_{\text{max}} = \frac{3V_\phi E_A}{X_S} \quad (5-21)$$

The maximum power indicated by this equation is called the *static stability limit* of the generator. Normally, real generators never even come close to that limit. Full-load torque angles of 15 to 20° are more typical of real machines.

Now take another look at Equations (5-17), (5-19), and (5-20). If  $V_\phi$  is assumed constant, then the *real power output is directly proportional* to the quantities  $I_A \cos \theta$  and  $E_A \sin \delta$ , and the reactive power output is directly proportional to the quantity  $I_A \sin \theta$ . These facts are useful in plotting phasor diagrams of synchronous generators as loads change.

From Chapter 4, the induced torque in this generator can be expressed as

$$\tau_{\text{ind}} = k\mathbf{B}_R \times \mathbf{B}_S \quad (4-58)$$

or as

$$\tau_{\text{ind}} = k\mathbf{B}_R \times \mathbf{B}_{\text{net}} \quad (4-60)$$



The magnitude of Equation (4-60) can be expressed as

$$\tau_{\text{ind}} = kB_R B_{\text{net}} \sin \delta \quad (4-61)$$

where  $\delta$  is the angle between the rotor and net magnetic fields (the so-called *torque angle*). Since  $B_R$  produces the voltage  $E_A$  and  $B_{\text{net}}$  produces the voltage  $V_\phi$ , the angle  $\delta$  between  $E_A$  and  $V_\phi$  is the same as the angle  $\delta$  between  $B_R$  and  $B_{\text{net}}$ .

An alternative expression for the induced torque in a synchronous generator can be derived from Equation (5-20). Because  $P_{\text{conv}} = \tau_{\text{ind}}\omega_m$ , the induced torque can be expressed as

$$\tau_{\text{ind}} = \frac{3V_\phi E_A \sin \delta}{\omega_m X_S} \quad (5-22)$$

This expression describes the induced torque in terms of electrical quantities, whereas Equation (4-60) gives the same information in terms of magnetic quantities.

## 5.7 MEASURING SYNCHRONOUS GENERATOR MODEL PARAMETERS

The equivalent circuit of a synchronous generator that has been derived contains three quantities that must be determined in order to completely describe the behavior of a real synchronous generator:

1. The relationship between field current and flux (and therefore between the field current and  $E_A$ )
2. The synchronous reactance
3. The armature resistance

This section describes a simple technique for determining these quantities in a synchronous generator.

The first step in the process is to perform the *open-circuit test* on the generator. To perform this test, the generator is turned at the rated speed, the terminals are disconnected from all loads, and the field current is set to zero. Then the field current is gradually increased in steps, and the terminal voltage is measured at each step along the way. With the terminals open,  $I_A = 0$ , so  $E_A$  is equal to  $V_\phi$ . It is thus possible to construct a plot of  $E_A$  or  $V_T$  versus  $I_F$  from this information. This plot is the so-called *open-circuit characteristic* (OCC) of a generator. With this characteristic, it is possible to find the internal generated voltage of the generator for any given field current. A typical open-circuit characteristic is shown in Figure 5-17a. Notice that at first the curve is almost perfectly linear, until some saturation is observed at high field currents. The unsaturated iron in the frame of the synchronous machine has a reluctance several thousand times lower than the air-gap reluctance, so at first almost *all* the magnetomotive force is across the air gap, and the resulting flux increase is linear. When the iron finally saturates, the reluctance of the iron

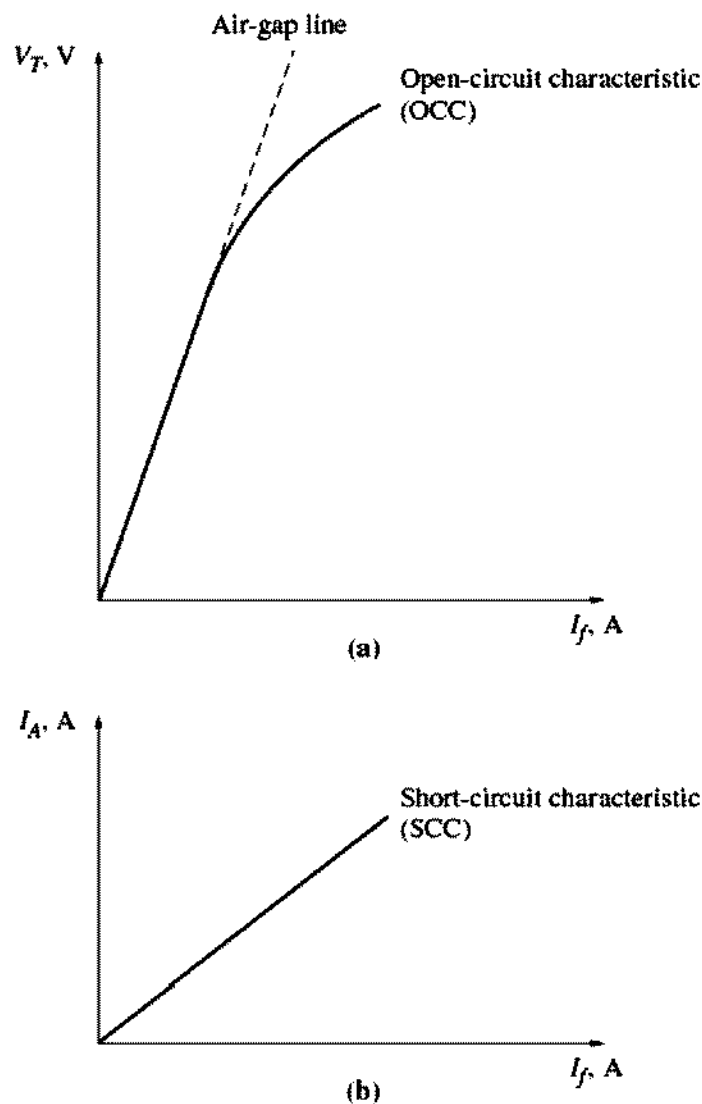

FIGURE 5-17

(a) The open-circuit characteristic (OCC) of a synchronous generator.  
 (b) The short-circuit characteristic (SCC) of a synchronous generator.

increases dramatically, and the flux increases much more slowly with an increase in magnetomotive force. The linear portion of an OCC is called the *air-gap line* of the characteristic.

The second step in the process is to conduct the *short-circuit test*. To perform the short-circuit test, adjust the field current to zero again and short-circuit the terminals of the generator through a set of ammeters. Then the armature current  $I_A$  or the line current  $I_L$  is measured as the field current is increased. Such a plot is called a *short-circuit characteristic* (SCC) and is shown in Figure 5-17b. It is essentially a straight line. To understand why this characteristic is a straight line, look at the equivalent circuit in Figure 5-12 when the terminals of the machine are short-circuited. Such a circuit is shown in Figure 5-18a. Notice that when the terminals are short-circuited, the armature current  $I_A$  is given by

$$I_A = \frac{E_A}{R_A + jX_S} \quad (5-23)$$

and its magnitude is just given by

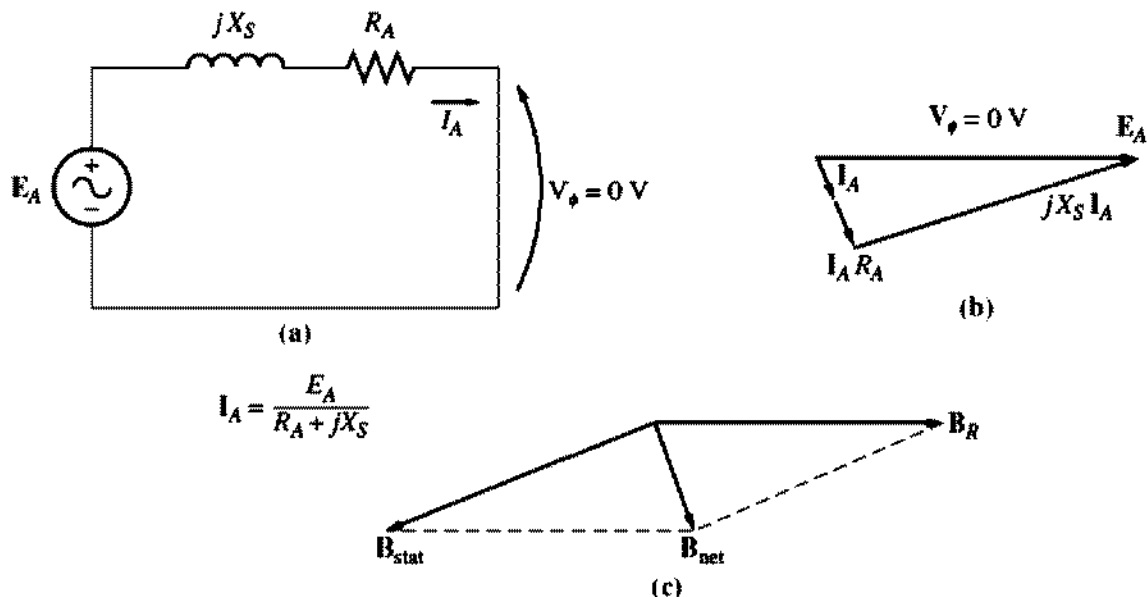
**FIGURE 5-18**

(a) The equivalent circuit of a synchronous generator during the short-circuit test. (b) The resulting phasor diagram. (c) The magnetic fields during the short-circuit test.

$$I_A = \frac{E_A}{\sqrt{R_A^2 + X_S^2}} \quad (5-24)$$

The resulting phasor diagram is shown in Figure 5-18b, and the corresponding magnetic fields are shown in Figure 5-18c. Since  $B_S$  almost cancels  $B_R$ , the net magnetic field  $B_{net}$  is very small (corresponding to internal resistive and inductive drops only). Since the net magnetic field in the machine is so small, the machine is unsaturated and the SCC is linear.

To understand what information these two characteristics yield, notice that, with  $V_\phi$  equal to zero in Figure 5-18, the *internal machine impedance* is given by

$$Z_S = \sqrt{R_A^2 + X_S^2} = \frac{E_A}{I_A} \quad (5-25)$$

Since  $X_S \gg R_A$ , this equation reduces to

$$X_S \approx \frac{E_A}{I_A} = \frac{V_{\phi,oc}}{I_A} \quad (5-26)$$

If  $E_A$  and  $I_A$  are known for a given situation, then the synchronous reactance  $X_S$  can be found.

Therefore, an *approximate* method for determining the synchronous reactance  $X_S$  at a given field current is

1. Get the internal generated voltage  $E_A$  from the OCC at that field current.
2. Get the short-circuit current flow  $I_{A,SC}$  at that field current from the SCC.
3. Find  $X_S$  by applying Equation (5-26).

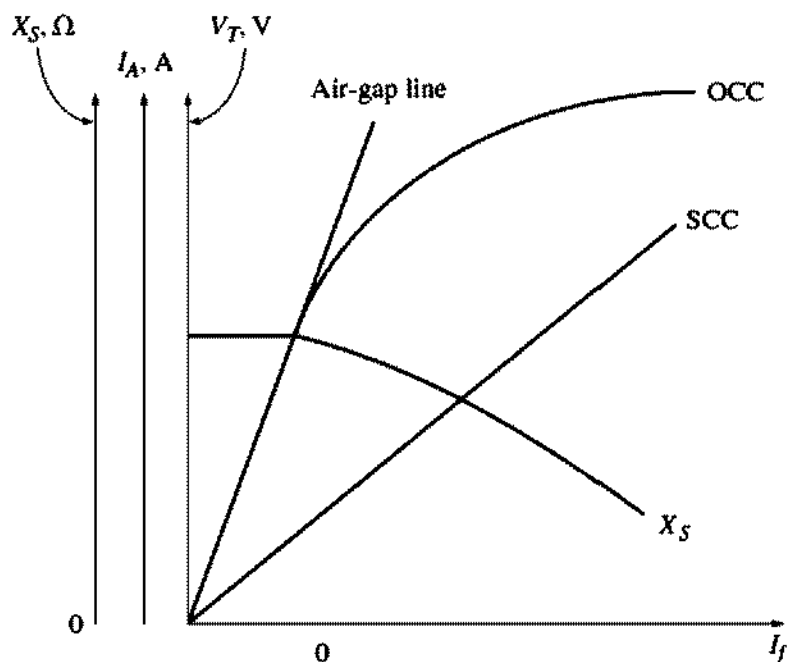

**FIGURE 5-19**

A sketch of the approximate synchronous reactance of a synchronous generator as a function of the field current in the machine. The constant value of reactance found at low values of field current is the *unsaturated* synchronous reactance of the machine.

There is a problem with this approach, however. The internal generated voltage  $E_A$  comes from the OCC, where the machine is partially *saturated* for large field currents, while  $I_A$  is taken from the SCC, where the machine is *unsaturated* at all field currents. Therefore, at higher field currents, the  $E_A$  taken from the OCC at a given field current is *not* the same as the  $E_A$  at the same field current under short-circuit conditions, and this difference makes the resulting value of  $X_s$  only approximate.

However, the answer given by this approach *is* accurate up to the point of saturation, so the *unsaturated synchronous reactance*  $X_{s,u}$  of the machine can be found simply by applying Equation (5-26) at any field current in the linear portion (on the air-gap line) of the OCC curve.

The approximate value of synchronous reactance varies with the degree of saturation of the OCC, so the value of the synchronous reactance to be used in a given problem should be one calculated at the approximate load on the machine. A plot of approximate synchronous reactance as a function of field current is shown in Figure 5-19.

To get a more accurate estimation of the saturated synchronous reactance, refer to Section 5-3 of Reference 2.

If it is important to know a winding's resistance as well as its synchronous reactance, the resistance can be approximated by applying a dc voltage to the windings while the machine is stationary and measuring the resulting current flow. The use of dc voltage means that the reactance of the windings will be zero during the measurement process.

This technique is not perfectly accurate, since the ac resistance will be slightly larger than the dc resistance (as a result of the skin effect at higher frequencies). The measured value of the resistance can even be plugged into Equation (5-26) to improve the estimate of  $X_S$ , if desired. (Such an improvement is not much help in the approximate approach—saturation causes a much larger error in the  $X_S$  calculation than ignoring  $R_A$  does.)

### The Short-Circuit Ratio

Another parameter used to describe synchronous generators is the short-circuit ratio. The *short-circuit ratio* of a generator is defined as the ratio of the *field current required for the rated voltage at open circuit* to the *field current required for the rated armature current at short circuit*. It can be shown that this quantity is just the reciprocal of the per-unit value of the approximate saturated synchronous reactance calculated by Equation (5-26).

Although the short-circuit ratio adds no new information about the generator that is not already known from the saturated synchronous reactance, it is important to know what it is, since the term is occasionally encountered in industry.

**Example 5-1.** A 200-kVA, 480-V, 50-Hz, Y-connected synchronous generator with a rated field current of 5 A was tested, and the following data were taken:

1.  $V_{T,OC}$  at the rated  $I_F$  was measured to be 540 V.
2.  $I_{L,SC}$  at the rated  $I_F$  was found to be 300 A.
3. When a dc voltage of 10 V was applied to two of the terminals, a current of 25 A was measured.

Find the values of the armature resistance and the approximate synchronous reactance in ohms that would be used in the generator model at the rated conditions.

#### Solution

The generator described above is Y-connected, so the direct current in the resistance test flows through two windings. Therefore, the resistance is given by

$$2R_A = \frac{V_{DC}}{I_{DC}}$$

$$R_A = \frac{V_{DC}}{2I_{DC}} = \frac{10 \text{ V}}{(2)(25 \text{ A})} = 0.2 \Omega$$

The internal generated voltage at the rated field current is equal to

$$E_A = V_{\phi,OC} = \frac{V_T}{\sqrt{3}}$$

$$= \frac{540 \text{ V}}{\sqrt{3}} = 311.8 \text{ V}$$

The short-circuit current  $I_A$  is just equal to the line current, since the generator is Y-connected:

$$I_{A,SC} = I_{L,SC} = 300 \text{ A}$$

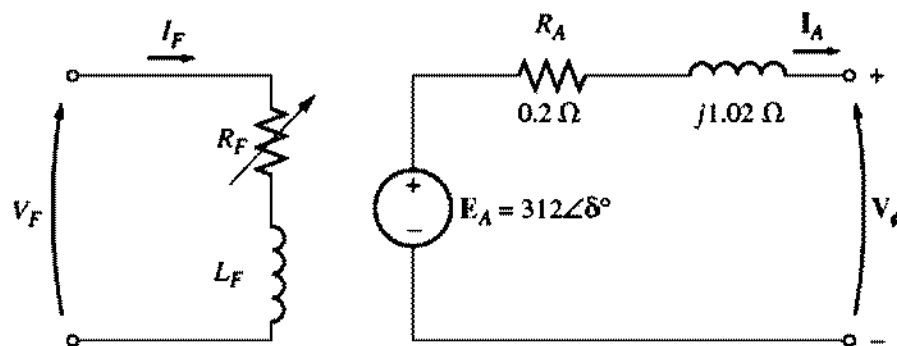

FIGURE 5-20

The per-phase equivalent circuit of the generator in Example 5-1.

Therefore, the synchronous reactance at the rated field current can be calculated from Equation (5-25):

$$\begin{aligned} \sqrt{R_A^2 + X_S^2} &= \frac{E_A}{I_A} & (5-25) \\ \sqrt{(0.2 \Omega)^2 + X_S^2} &= \frac{311.8 \text{ V}}{300 \text{ A}} \\ \sqrt{(0.2 \Omega)^2 + X_S^2} &= 1.039 \Omega \\ 0.04 + X_S^2 &= 1.08 \\ X_S^2 &= 1.04 \\ X_S &= 1.02 \Omega \end{aligned}$$

How much effect did the inclusion of  $R_A$  have on the estimate of  $X_S$ ? Not much. If  $X_S$  is evaluated by Equation (5-26), the result is

$$X_S = \frac{E_A}{I_A} = \frac{311.8 \text{ V}}{300 \text{ A}} = 1.04 \Omega$$

Since the error in  $X_S$  due to ignoring  $R_A$  is much less than the error due to saturation effects, approximate calculations are normally done with Equation (5-26).

The resulting per-phase equivalent circuit is shown in Figure 5-20.

## 5.8 THE SYNCHRONOUS GENERATOR OPERATING ALONE

The behavior of a synchronous generator under load varies greatly depending on the power factor of the load and on whether the generator is operating alone or in parallel with other synchronous generators. In this section, we will study the behavior of synchronous generators operating alone. We will study the behavior of synchronous generators operating in parallel in Section 5.9.

Throughout this section, concepts will be illustrated with simplified phasor diagrams ignoring the effect of  $R_A$ . In some of the numerical examples the resistance  $R_A$  will be included.

Unless otherwise stated in this section, the speed of the generators will be assumed constant, and all terminal characteristics are drawn assuming constant

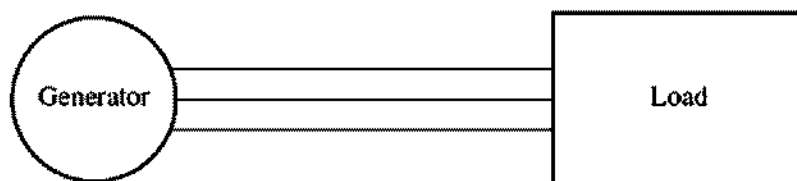

**FIGURE 5–21**  
A single generator supplying a load.

speed. Also, the rotor flux in the generators is assumed constant unless their field current is explicitly changed.

### The Effect of Load Changes on a Synchronous Generator Operating Alone

To understand the operating characteristics of a synchronous generator operating alone, examine a generator supplying a load. A diagram of a single generator supplying a load is shown in Figure 5–21. What happens when we increase the load on this generator?

An increase in the load is an increase in the real and/or reactive power drawn from the generator. Such a load increase increases the load current drawn from the generator. Because the field resistor has not been changed, the field current is constant, and therefore the flux  $\phi$  is constant. Since the prime mover also keeps a constant speed  $\omega$ , the *magnitude of the internal generated voltage*  $E_A = K\phi\omega$  is constant.

If  $E_A$  is constant, just what does vary with a changing load? The way to find out is to construct phasor diagrams showing an increase in the load, keeping the constraints on the generator in mind.

First, examine a generator operating at a lagging power factor. If more load is added at the *same power factor*, then  $|I_A|$  increases but remains at the same angle  $\theta$  with respect to  $V_\phi$  as before. Therefore, the armature reaction voltage  $jX_S I_A$  is larger than before but at the same angle. Now since

$$E_A = V_\phi + jX_S I_A$$

$jX_S I_A$  must stretch between  $V_\phi$  at an angle of  $0^\circ$  and  $E_A$ , which is constrained to be of the same magnitude as before the load increase. If these constraints are plotted on a phasor diagram, there is one and only one point at which the armature reaction voltage can be parallel to its original position while increasing in size. The resulting plot is shown in Figure 5–22a.

If the constraints are observed, then it is seen that as the load increases, the voltage  $V_\phi$  decreases rather sharply.

Now suppose the generator is loaded with unity-power-factor loads. What happens if new loads are added at the same power factor? With the same constraints as before, it can be seen that this time  $V_\phi$  decreases only slightly (see Figure 5–22b).

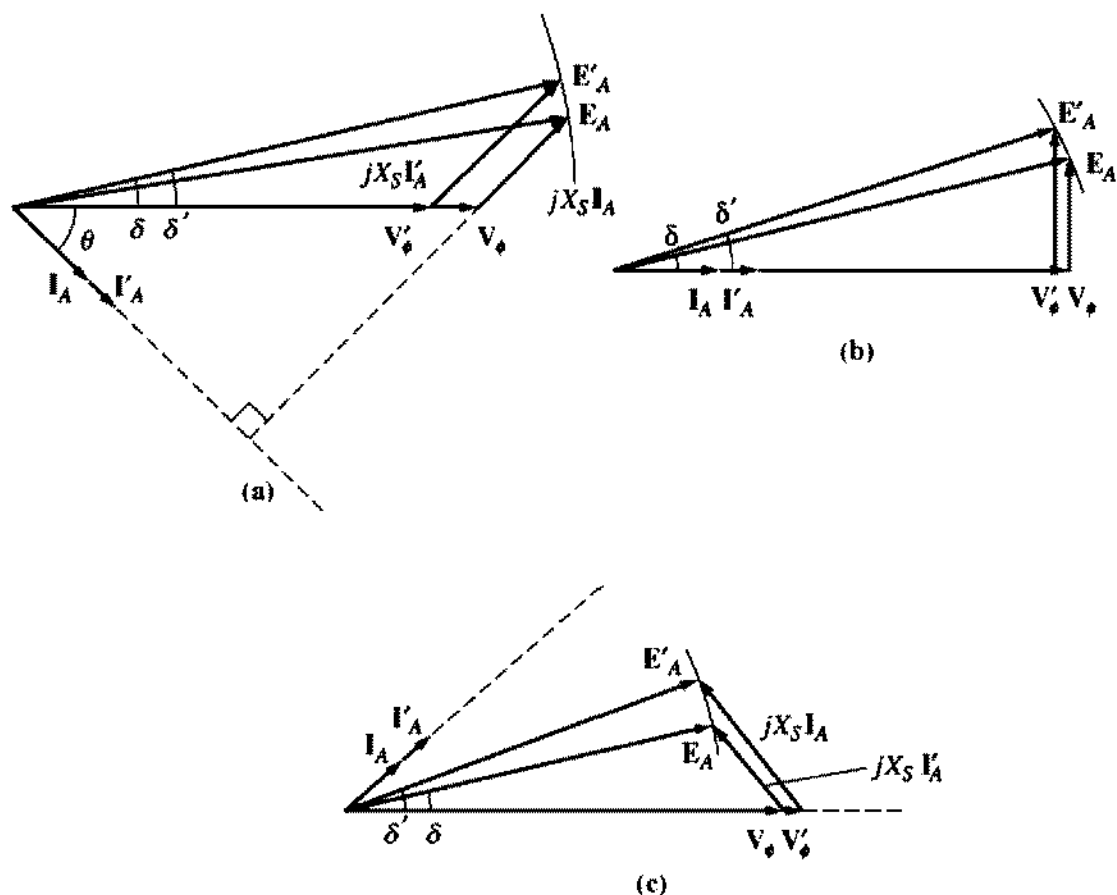

**FIGURE 5-22**  
 The effect of an increase in generator loads at constant power factor upon its terminal voltage. (a) Lagging power factor; (b) unity power factor; (c) leading power factor.

Finally, let the generator be loaded with leading-power-factor loads. If new loads are added at the same power factor this time, the armature reaction voltage lies outside its previous value, and  $V_\phi$  actually *rises* (see Figure 5-22c). In this last case, an increase in the load in the generator produced an increase in the terminal voltage. Such a result is not something one would expect on the basis of intuition alone.

General conclusions from this discussion of synchronous generator behavior are

1. If lagging loads (+ $Q$  or inductive reactive power loads) are added to a generator,  $V_\phi$  and the terminal voltage  $V_T$  decrease significantly.
2. If unity-power-factor loads (no reactive power) are added to a generator, there is a slight decrease in  $V_\phi$  and the terminal voltage.
3. If leading loads ( $-Q$  or capacitive reactive power loads) are added to a generator,  $V_\phi$  and the terminal voltage will rise.

A convenient way to compare the voltage behavior of two generators is by their *voltage regulation*. The voltage regulation (VR) of a generator is defined by the equation



$$\text{VR} = \frac{V_{nl} - V_{fl}}{V_{fl}} \times 100\% \quad (4-67)$$

where  $V_{nl}$  is the no-load voltage of the generator and  $V_{fl}$  is the full-load voltage of the generator. A synchronous generator operating at a lagging power factor has a fairly large positive voltage regulation, a synchronous generator operating at a unity power factor has a small positive voltage regulation, and a synchronous generator operating at a leading power factor often has a negative voltage regulation.

Normally, it is desirable to keep the voltage supplied to a load constant, even though the load itself varies. How can terminal voltage variations be corrected for? The obvious approach is to vary the magnitude of  $E_A$  to compensate for changes in the load. Recall that  $E_A = K\phi\omega$ . Since the frequency should not be changed in a normal system,  $E_A$  must be controlled by varying the flux in the machine.

For example, suppose that a lagging load is added to a generator. Then the terminal voltage will fall, as was previously shown. To restore it to its previous level, decrease the field resistor  $R_F$ . If  $R_F$  decreases, the field current will increase. An increase in  $I_F$  increases the flux, which in turn increases  $E_A$ , and an increase in  $E_A$  increases the phase and terminal voltage. This idea can be summarized as follows:

1. Decreasing the field resistance in the generator increases its field current.
2. An increase in the field current increases the flux in the machine.
3. An increase in the flux increases the internal generated voltage  $E_A = K\phi\omega$ .
4. An increase in  $E_A$  increases  $V_\phi$  and the terminal voltage of the generator.

The process can be reversed to decrease the terminal voltage. It is possible to regulate the terminal voltage of a generator throughout a series of load changes simply by adjusting the field current.

### Example Problems

The following three problems illustrate simple calculations involving voltages, currents, and power flows in synchronous generators. The first problem is an example that includes the armature resistance in its calculations, while the next two ignore  $R_A$ . Part of the first example problem addresses the question: *How must a generator's field current be adjusted to keep  $V_T$  constant as the load changes?* On the other hand, part of the second example problem asks the question: *If the load changes and the field is left alone, what happens to the terminal voltage?* You should compare the calculated behavior of the generators in these two problems to see if it agrees with the qualitative arguments of this section. Finally, the third example illustrates the use of a MATLAB program to derive the terminal characteristics of synchronous generator.

**Example 5-2.** A 480-V, 60-Hz,  $\Delta$ -connected, four-pole synchronous generator has the OCC shown in Figure 5-23a. This generator has a synchronous reactance of 0.1  $\Omega$  and

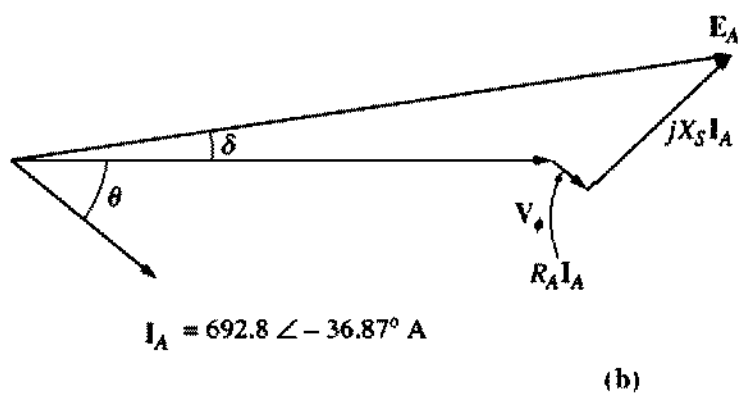
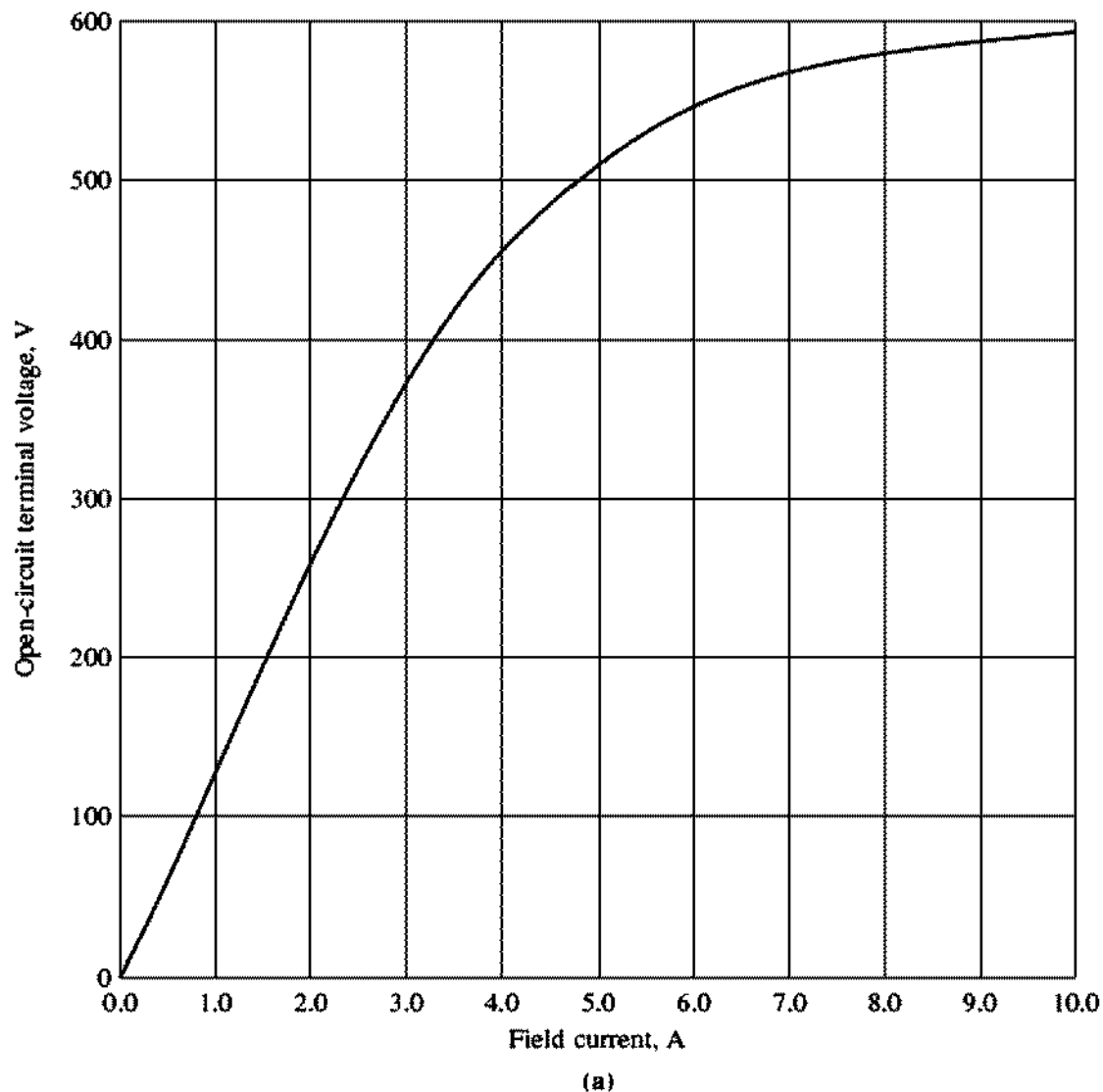

**FIGURE 5-23**  
 (a) Open-circuit characteristic of the generator in Example 5-2. (b) Phasor diagram of the generator in Example 5-2.

an armature resistance of  $0.015 \Omega$ . At full load, the machine supplies 1200 A at 0.8 PF lagging. Under full-load conditions, the friction and windage losses are 40 kW, and the core losses are 30 kW. Ignore any field circuit losses.

- (a) What is the speed of rotation of this generator?  
 (b) How much field current must be supplied to the generator to make the terminal voltage 480 V at no load?  
 (c) If the generator is now connected to a load and the load draws 1200 A at 0.8 PF lagging, how much field current will be required to keep the terminal voltage equal to 480 V?  
 (d) How much power is the generator now supplying? How much power is supplied to the generator by the prime mover? What is this machine's overall efficiency?  
 (e) If the generator's load were suddenly disconnected from the line, what would happen to its terminal voltage?  
 (f) Finally, suppose that the generator is connected to a load drawing 1200 A at 0.8 PF leading. How much field current would be required to keep  $V_T$  at 480 V?

### Solution

This synchronous generator is  $\Delta$ -connected, so its phase voltage is equal to its line voltage  $V_\phi = V_T$ , while its phase current is related to its line current by the equation  $I_L = \sqrt{3}I_\phi$ .

- (a) The relationship between the electrical frequency produced by a synchronous generator and the mechanical rate of shaft rotation is given by Equation (4-34):

$$f_e = \frac{n_m P}{120} \quad (4-34)$$

Therefore,

$$\begin{aligned} n_m &= \frac{120f_e}{P} \\ &= \frac{120(60 \text{ Hz})}{4 \text{ poles}} = 1800 \text{ r/min} \end{aligned}$$

- (b) In this machine,  $V_T = V_\phi$ . Since the generator is at no load,  $I_A = 0$  and  $E_A = V_\phi$ . Therefore,  $V_T = V_\phi = E_A = 480 \text{ V}$ , and from the open-circuit characteristic,  $I_F = 4.5 \text{ A}$ .  
 (c) If the generator is supplying 1200 A, then the armature current in the machine is

$$I_A = \frac{1200 \text{ A}}{\sqrt{3}} = 692.8 \text{ A}$$

The phasor diagram for this generator is shown in Figure 5-23b. If the terminal voltage is adjusted to be 480 V, the size of the internal generated voltage  $E_A$  is given by

$$\begin{aligned} E_A &= V_\phi + R_A I_A + jX_S I_A \\ &= 480 \angle 0^\circ \text{ V} + (0.015 \Omega)(692.8 \angle -36.87^\circ \text{ A}) + (j0.1 \Omega)(692.8 \angle -36.87^\circ \text{ A}) \\ &= 480 \angle 0^\circ \text{ V} + 10.39 \angle -36.87^\circ \text{ V} + 69.28 \angle 53.13^\circ \text{ V} \\ &= 529.9 + j49.2 \text{ V} = 532 \angle 5.3^\circ \text{ V} \end{aligned}$$

To keep the terminal voltage at 480 V,  $E_A$  must be adjusted to 532 V. From Figure 5-23, the required field current is 5.7 A.

- (d) The power that the generator is now supplying can be found from Equation (5-16):

$$P_{\text{out}} = \sqrt{3}V_T I_L \cos \theta \quad (5-16)$$

$$\begin{aligned}
 &= \sqrt{3}(480 \text{ V})(1200 \text{ A}) \cos 36.87^\circ \\
 &= 798 \text{ kW}
 \end{aligned}$$

To determine the power input to the generator, use the power-flow diagram (Figure 5-15). From the power-flow diagram, the mechanical input power is given by

$$P_{\text{in}} = P_{\text{out}} + P_{\text{elec loss}} + P_{\text{core loss}} + P_{\text{mech loss}} + P_{\text{stray loss}}$$

The stray losses were not specified here, so they will be ignored. In this generator, the electrical losses are

$$\begin{aligned}
 P_{\text{elec loss}} &= 3I_A^2 R_A \\
 &= 3(692.8 \text{ A})^2(0.015 \Omega) = 21.6 \text{ kW}
 \end{aligned}$$

The core losses are 30 kW, and the friction and windage losses are 40 kW, so the total input power to the generator is

$$P_{\text{in}} = 798 \text{ kW} + 21.6 \text{ kW} + 30 \text{ kW} + 40 \text{ kW} = 889.6 \text{ kW}$$

Therefore, the machine's overall efficiency is

$$\eta = \frac{P_{\text{out}}}{P_{\text{in}}} \times 100\% = \frac{798 \text{ kW}}{889.6 \text{ kW}} \times 100\% = 89.75\%$$

- (e) If the generator's load were suddenly disconnected from the line, the current  $I_A$  would drop to zero, making  $E_A = V_\phi$ . Since the field current has not changed,  $|E_A|$  has not changed and  $V_\phi$  and  $V_T$  must rise to equal  $E_A$ . Therefore, if the load were suddenly dropped, the terminal voltage of the generator would rise to 532 V.
- (f) If the generator were loaded down with 1200 A at 0.8 PF leading while the terminal voltage was 480 V, then the internal generated voltage would have to be

$$\begin{aligned}
 E_A &= V_\phi + R_A I_A + jX_S I_A \\
 &= 480 \angle 0^\circ \text{ V} + (0.015 \Omega)(692.8 \angle 36.87^\circ \text{ A}) + (j0.1 \Omega)(692.8 \angle 36.87^\circ \text{ A}) \\
 &= 480 \angle 0^\circ \text{ V} + 10.39 \angle 36.87^\circ \text{ V} + 69.28 \angle 126.87^\circ \text{ V} \\
 &= 446.7 + j61.7 \text{ V} = 451 \angle 7.1^\circ \text{ V}
 \end{aligned}$$

Therefore, the internal generated voltage  $E_A$  must be adjusted to provide 451 V if  $V_T$  is to remain 480 V. Using the open-circuit characteristic, the field current would have to be adjusted to 4.1 A.

Which type of load (leading or lagging) needed a larger field current to maintain the rated voltage? Which type of load (leading or lagging) placed more thermal stress on the generator? Why?

**Example 5-3.** A 480-V, 50-Hz, Y-connected, six-pole synchronous generator has a per-phase synchronous reactance of 1.0  $\Omega$ . Its full-load armature current is 60 A at 0.8 PF lagging. This generator has friction and windage losses of 1.5 kW and core losses of 1.0 kW at 60 Hz at full load. Since the armature resistance is being ignored, assume that the  $I^2R$  losses are negligible. The field current has been adjusted so that the terminal voltage is 480 V at no load.

- (a) What is the speed of rotation of this generator?  
 (b) What is the terminal voltage of this generator if the following are true?

1. It is loaded with the rated current at 0.8 PF lagging.
  2. It is loaded with the rated current at 1.0 PF.
  3. It is loaded with the rated current at 0.8 PF leading.
- (c) What is the efficiency of this generator (ignoring the unknown electrical losses) when it is operating at the rated current and 0.8 PF lagging?
- (d) How much shaft torque must be applied by the prime mover at full load? How large is the induced countertorque?
- (e) What is the voltage regulation of this generator at 0.8 PF lagging? At 1.0 PF? At 0.8 PF leading?

### Solution

This generator is Y-connected, so its phase voltage is given by  $V_\phi = V_T/\sqrt{3}$ . That means that when  $V_T$  is adjusted to 480 V,  $V_\phi = 277$  V. The field current has been adjusted so that  $V_{T,0} = 480$  V, so  $V_\phi = 277$  V. At *no load*, the armature current is zero, so the armature reaction voltage and the  $I_A R_A$  drops are zero. Since  $I_A = 0$ , the internal generated voltage  $E_A = V_\phi = 277$  V. The internal generated voltage  $E_A (= K\phi\omega)$  varies only when the field current changes. Since the problem states that the field current is adjusted initially and then left alone, the magnitude of the internal generated voltage is  $E_A = 277$  V and will not change in this example.

- (a) The speed of rotation of a synchronous generator in revolutions per minute is given by Equation (4-34):

$$f_e = \frac{n_m P}{120} \quad (4-34)$$

Therefore,

$$\begin{aligned} n_m &= \frac{120f_e}{P} \\ &= \frac{120(50 \text{ Hz})}{6 \text{ poles}} = 1000 \text{ r/min} \end{aligned}$$

Alternatively, the speed expressed in radians per second is

$$\begin{aligned} \omega_m &= (1000 \text{ r/min}) \left( \frac{1 \text{ min}}{60 \text{ s}} \right) \left( \frac{2\pi \text{ rad}}{1 \text{ r}} \right) \\ &= 104.7 \text{ rad/s} \end{aligned}$$

- (b) 1. If the generator is loaded down with rated current at 0.8 PF lagging, the resulting phasor diagram looks like the one shown in Figure 5-24a. In this phasor diagram, we know that  $V_\phi$  is at an angle of  $0^\circ$ , that the magnitude of  $E_A$  is 277 V, and that the quantity  $jX_S I_A$  is

$$jX_S I_A = j(1.0 \Omega)(60 \angle -36.87^\circ \text{ A}) = 60 \angle 53.13^\circ \text{ V}$$

The two quantities not known on the voltage diagram are the magnitude of  $V_\phi$  and the angle  $\delta$  of  $E_A$ . To find these values, the easiest approach is to construct a right triangle on the phasor diagram, as shown in the figure. From Figure 5-24a, the right triangle gives

$$E_A^2 = (V_\phi + X_S I_A \sin \theta)^2 + (X_S I_A \cos \theta)^2$$

Therefore, the phase voltage at the rated load and 0.8 PF lagging is

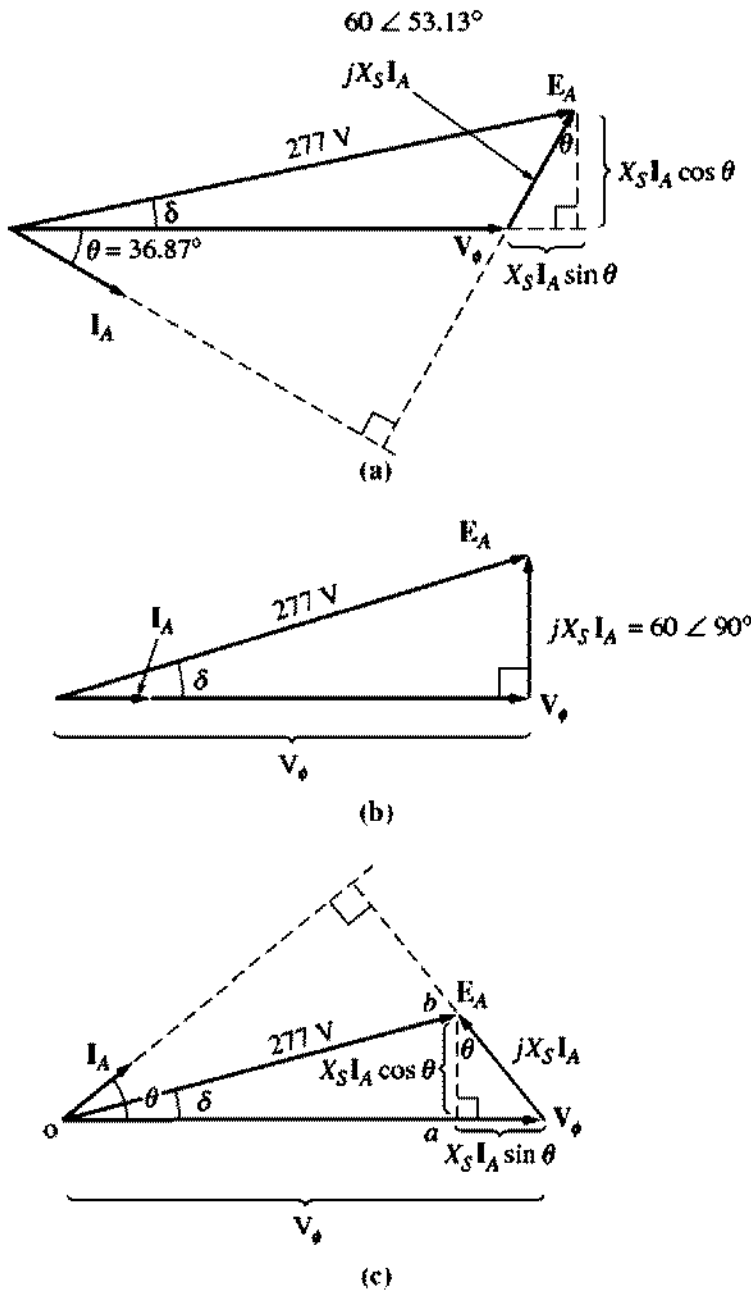

**FIGURE 5-24**  
 Generator phasor diagrams for Example 5-3. (a) Lagging power factor; (b) unity power factor; (c) leading power factor.

$$\begin{aligned}
 (277 \text{ V})^2 &= [V_\phi + (1.0 \Omega)(60 \text{ A}) \sin 36.87^\circ]^2 + [(1.0 \Omega)(60 \text{ A}) \cos 36.87^\circ]^2 \\
 76,729 &= (V_\phi + 36)^2 + 2304 \\
 74,425 &= (V_\phi + 36)^2 \\
 272.8 &= V_\phi + 36 \\
 V_\phi &= 236.8 \text{ V}
 \end{aligned}$$

Since the generator is Y-connected,  $V_T = \sqrt{3}V_\phi = 410 \text{ V}$ .

2. If the generator is loaded with the rated current at unity power factor, then the phasor diagram will look like Figure 5-24b. To find  $V_\phi$  here the right triangle is

$$\begin{aligned}
 E_A^2 &= V_\phi^2 + (X_S I_A)^2 \\
 (277 \text{ V})^2 &= V_\phi^2 + [(1.0 \Omega)(60 \text{ A})]^2 \\
 76,729 &= V_\phi^2 + 3600 \\
 V_\phi^2 &= 73,129 \\
 V_\phi &= 270.4 \text{ V}
 \end{aligned}$$

Therefore,  $V_T = \sqrt{3}V_\phi = 468.4 \text{ V}$ .

3. When the generator is loaded with the rated current at 0.8 PF leading, the resulting phasor diagram is the one shown in Figure 5-24c. To find  $V_\phi$  in this situation, we construct the triangle  $OAB$  shown in the figure. The resulting equation is

$$E_A^2 = (V_\phi - X_S I_A)^2 + (X_S I_A \cos \theta)^2$$

Therefore, the phase voltage at the rated load and 0.8 PF leading is

$$\begin{aligned}
 (277 \text{ V})^2 &= [V_\phi - (1.0 \Omega)(60 \text{ A}) \sin 36.87^\circ]^2 + [(1.0 \Omega)(60 \text{ A}) \cos 36.87^\circ]^2 \\
 76,729 &= (V_\phi - 36)^2 + 2304 \\
 74,425 &= (V_\phi - 36)^2 \\
 272.8 &= V_\phi - 36 \\
 V_\phi &= 308.8 \text{ V}
 \end{aligned}$$

Since the generator is Y-connected,  $V_T = \sqrt{3}V_\phi = 535 \text{ V}$ .

- (c) The output power of this generator at 60 A and 0.8 PF lagging is

$$\begin{aligned}
 P_{\text{out}} &= 3V_\phi I_A \cos \theta \\
 &= 3(236.8 \text{ V})(60 \text{ A})(0.8) = 34.1 \text{ kW}
 \end{aligned}$$

The mechanical input power is given by

$$\begin{aligned}
 P_{\text{in}} &= P_{\text{out}} + P_{\text{elec loss}} + P_{\text{core loss}} + P_{\text{mech loss}} \\
 &= 34.1 \text{ kW} + 0 + 1.0 \text{ kW} + 1.5 \text{ kW} = 36.6 \text{ kW}
 \end{aligned}$$

The efficiency of the generator is thus

$$\eta = \frac{P_{\text{out}}}{P_{\text{in}}} \times 100\% = \frac{34.1 \text{ kW}}{36.6 \text{ kW}} \times 100\% = 93.2\%$$

- (d) The input torque to this generator is given by the equation

$$P_{\text{in}} = \tau_{\text{app}} \omega_m$$

so 
$$\tau_{\text{app}} = \frac{P_{\text{in}}}{\omega_m} = \frac{36.6 \text{ kW}}{125.7 \text{ rad/s}} = 291.2 \text{ N} \cdot \text{m}$$

The induced countertorque is given by

$$P_{\text{conv}} = \tau_{\text{app}} \omega_m$$

so 
$$\tau_{\text{ind}} = \frac{P_{\text{conv}}}{\omega_v} = \frac{34.1 \text{ kW}}{125.7 \text{ rad/s}} = 271.3 \text{ N} \cdot \text{m}$$

- (e) The voltage regulation of a generator is defined as

$$VR = \frac{V_{nl} - V_n}{V_n} \times 100\% \quad (4-67)$$

By this definition, the voltage regulation for the lagging, unity, and leading power-factor cases are

1. Lagging case:  $VR = \frac{480 \text{ V} - 410 \text{ V}}{410 \text{ V}} \times 100\% = 17.1\%$
2. Unity case:  $VR = \frac{480 \text{ V} - 468 \text{ V}}{468 \text{ V}} \times 100\% = 2.6\%$
3. Leading case:  $VR = \frac{480 \text{ V} - 535 \text{ V}}{535 \text{ V}} \times 100\% = -10.3\%$

In Example 5-3, lagging loads resulted in a drop in terminal voltage, unity-power-factor loads caused little effect on  $V_T$ , and leading loads resulted in an increase in terminal voltage.

**Example 5-4.** Assume that the generator of Example 5-3 is operating at no load with a terminal voltage of 480 V. Plot the terminal characteristic (terminal voltage versus line current) of this generator as its armature current varies from no-load to full load at a power factor of (a) 0.8 lagging and (b) 0.8 leading. Assume that the field current remains constant at all times.

#### Solution

The terminal characteristic of a generator is a plot of its terminal voltage versus line current. Since this generator is Y-connected, its phase voltage is given by  $V_\phi = V_T/\sqrt{3}$ . If  $V_T$  is adjusted to 480 V at no-load conditions, then  $V_\phi = E_A = 277$  V. Because the field current remains constant,  $E_A$  will remain 277 V at all times. The output current  $I_L$  from this generator will be the same as its armature current  $I_A$  because it is Y-connected.

- (a) If the generator is loaded with a 0.8 PF lagging current, the resulting phasor diagram looks like the one shown in Figure 5-24a. In this phasor diagram, we know that  $V_\phi$  is at an angle of  $0^\circ$ , that the magnitude of  $E_A$  is 277 V, and that the quantity  $jX_S I_A$  stretches between  $V_\phi$  and  $E_A$  as shown. The two quantities not known on the phasor diagram are the magnitude of  $V_\phi$  and the angle  $\delta$  of  $E_A$ . To find  $V_\phi$ , the easiest approach is to construct a right triangle on the phasor diagram, as shown in the figure. From Figure 5-24a, the right triangle gives

$$E_A^2 = (V_\phi + X_S I_A \sin \theta)^2 + (X_S I_A \cos \theta)^2$$

This equation can be used to solve for  $V_\phi$  as a function of the current  $I_A$ :

$$V_\phi = \sqrt{E_A^2 - (X_S I_A \cos \theta)^2} - X_S I_A \sin \theta$$

A simple MATLAB M-file can be used to calculate  $V_\phi$  (and hence  $V_T$ ) as a function of current. Such an M-file is shown below:

```
% M-file: term_char_a.m
% M-file to plot the terminal characteristics of the
% generator of Example 5-4 with an 0.8 PF lagging load.

% First, initialize the current amplitudes (21 values
% in the range 0-60 A)
i_a = (0:1:20) * 3;
```



```

% Now initialize all other values
v_phase = zeros(1,21);
e_a = 277.0;
x_s = 1.0;
theta = 36.87 * (pi/180); % Converted to radians

% Now calculate v_phase for each current level
for ii = 1:21
    v_phase(ii) = sqrt(e_a^2 - (x_s * i_a(ii) * cos(theta))^2) ...
                - (x_s * i_a(ii) * sin(theta));
end

% Calculate terminal voltage from the phase voltage
v_t = v_phase * sqrt(3);

% Plot the terminal characteristic, remembering the
% the line current is the same as i_a
plot(i_a,v_t,'Color','k','Linewidth',2.0);
xlabel('Line Current (A)','Fontweight','Bold');
ylabel('Terminal Voltage (V)','Fontweight','Bold');
title('Terminal Characteristic for 0.8 PF lagging load', ...
      'Fontweight','Bold');
grid on;
axis([0 60 400 550]);

```

The plot resulting when this M-file is executed is shown in Figure 5–25a.

- (b) If the generator is loaded with a 0.8 PF leading current, the resulting phasor diagram looks like the one shown in Figure 5–24c. To find  $V_\phi$ , the easiest approach is to construct a right triangle on the phasor diagram, as shown in the figure. From Figure 5–24c, the right triangle gives

$$E_A^2 = (V_\phi - X_S I_A \sin \theta)^2 + (X_S I_A \cos \theta)^2$$

This equation can be used to solve for  $V_\phi$  as a function of the current  $I_A$ :

$$V_\phi = \sqrt{E_A^2 - (X_S I_A \cos \theta)^2} + X_S I_A \sin \theta$$

This equation can be used to calculate and plot the terminal characteristic in a manner similar to that in part *a* above. The resulting terminal characteristic is shown in Figure 5–25b.

## 5.9 PARALLEL OPERATION OF AC GENERATORS

In today's world, an isolated synchronous generator supplying its own load independently of other generators is very rare. Such a situation is found in only a few out-of-the-way applications such as emergency generators. For all usual generator applications, there is more than one generator operating in parallel to supply the power demanded by the loads. An extreme example of this situation is the U.S. power grid, in which literally thousands of generators share the load on the system.

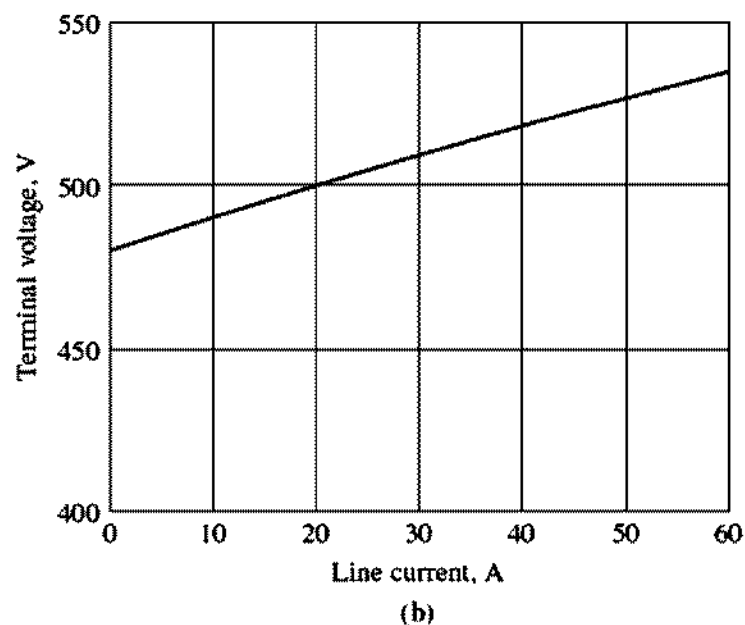
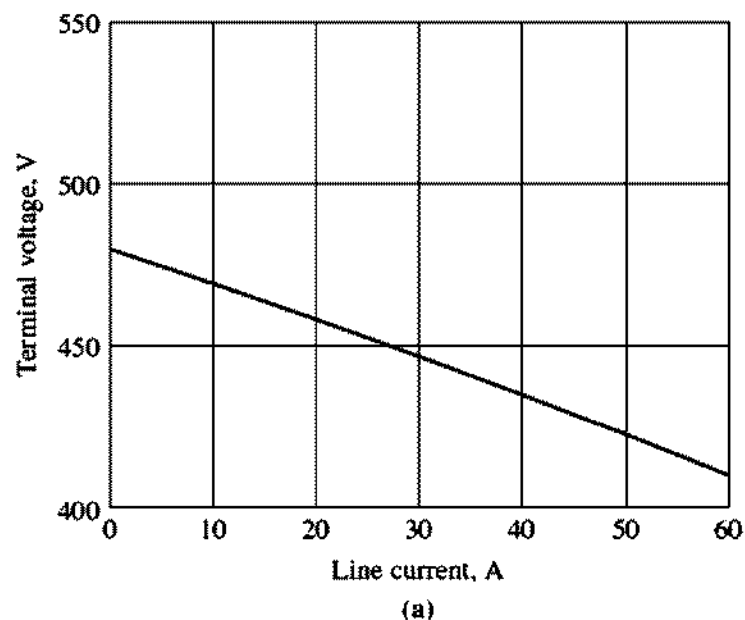

**FIGURE 5-25**

(a) Terminal characteristic for the generator of Example 5-4 when loaded with an 0.8 PF lagging load. (b) Terminal characteristic for the generator when loaded with an 0.8 PF leading load.

Why are synchronous generators operated in parallel? There are several major advantages to such operation:

1. Several generators can supply a bigger load than one machine by itself.
2. Having many generators increases the reliability of the power system, since the failure of any one of them does not cause a total power loss to the load.
3. Having many generators operating in parallel allows one or more of them to be removed for shutdown and preventive maintenance.

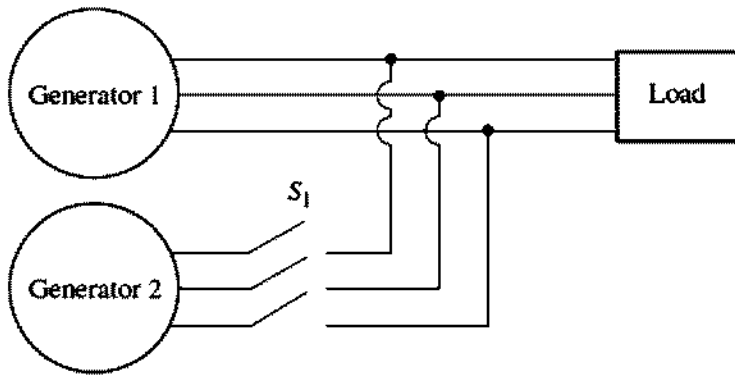

FIGURE 5-26

A generator being paralleled with a running power system.

4. If only one generator is used and it is not operating at near full load, then it will be relatively inefficient. With several smaller machines in parallel, it is possible to operate only a fraction of them. The ones that do operate are operating near full load and thus more efficiently.

This section explores the requirements for paralleling ac generators, and then looks at the behavior of synchronous generators operated in parallel.

### The Conditions Required for Paralleling

Figure 5-26 shows a synchronous generator  $G_1$  supplying power to a load, with another generator  $G_2$  about to be paralleled with  $G_1$  by closing the switch  $S_1$ . What conditions must be met before the switch can be closed and the two generators connected?

If the switch is closed arbitrarily at some moment, the generators are liable to be severely damaged, and the load may lose power. If the voltages are not exactly the same in each conductor being tied together, there will be a *very* large current flow when the switch is closed. To avoid this problem, each of the three phases must have *exactly the same voltage magnitude and phase angle* as the conductor to which it is connected. In other words, the voltage in phase  $a$  must be *exactly* the same as the voltage in phase  $a'$ , and so forth for phases  $b-b'$  and  $c-c'$ . To achieve this match, the following *paralleling conditions* must be met:

1. The rms *line voltages* of the two generators must be equal.
2. The two generators must have the same *phase sequence*.
3. The phase angles of the two  $a$  phases must be equal.
4. The frequency of the new generator, called the *oncoming generator*, must be slightly higher than the frequency of the running system.

These paralleling conditions require some explanation. Condition 1 is obvious—in order for two sets of voltages to be identical, they must of course have the same rms magnitude of voltage. The voltage in phases  $a$  and  $a'$  will be completely

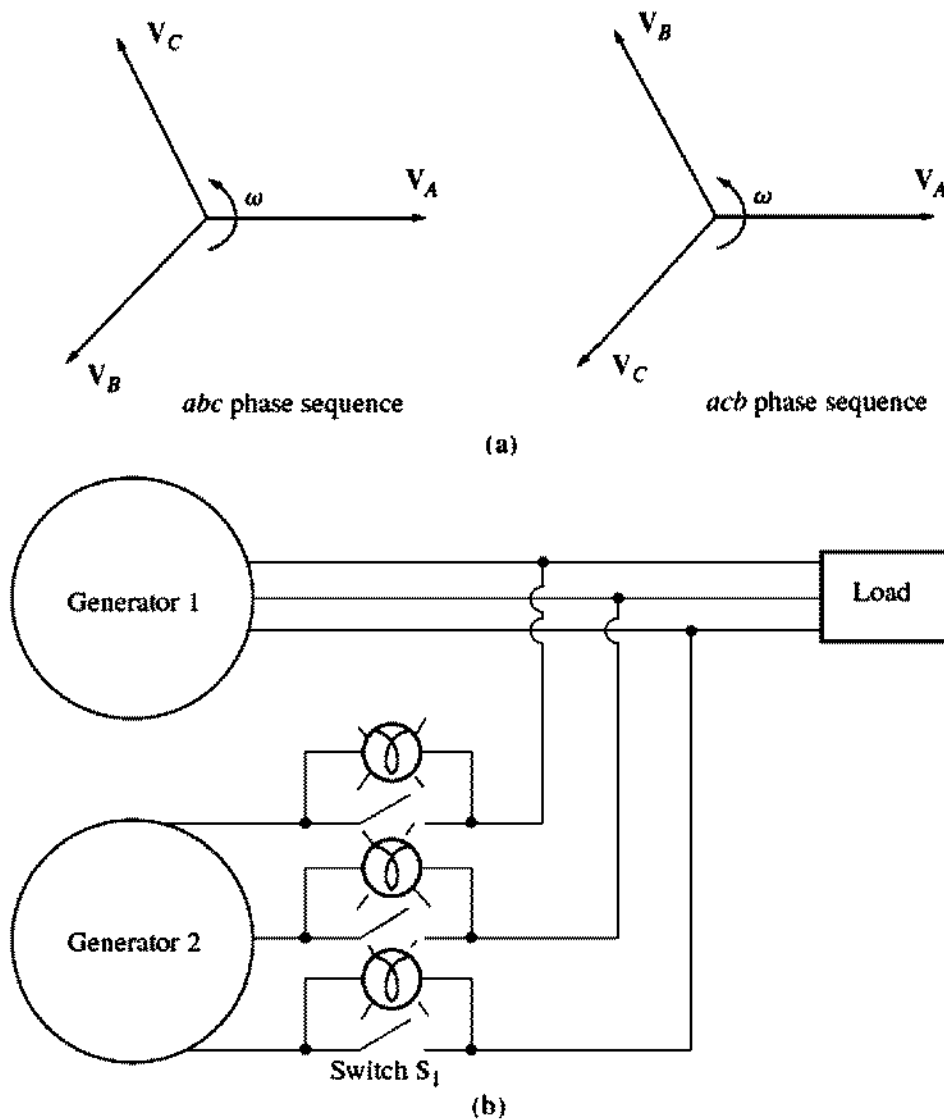

FIGURE 5-27

(a) The two possible phase sequences of a three-phase system. (b) The three-light-bulb method for checking phase sequence.

identical at all times if both their magnitudes and their angles are the same, which explains condition 3.

Condition 2 ensures that the sequence in which the phase voltages peak in the two generators is the same. If the phase sequence is different (as shown in Figure 5-27a), then even though one pair of voltages (the *a* phases) are in phase, the other two pairs of voltages are  $120^\circ$  out of phase. If the generators were connected in this manner, there would be no problem with phase *a*, but huge currents would flow in phases *b* and *c*, damaging both machines. To correct a phase sequence problem, simply swap the connections on any two of the three phases on one of the machines.

If the frequencies of the generators are not very nearly equal when they are connected together, large power transients will occur until the generators stabilize at a common frequency. The frequencies of the two machines must be very nearly equal, but they cannot be exactly equal. They must differ by a small amount so

that the phase angles of the oncoming machine will change slowly with respect to the phase angles of the running system. In that way, the angles between the voltages can be observed and switch  $S_1$  can be closed when the systems are exactly in phase.

### The General Procedure for Paralleling Generators

Suppose that generator  $G_2$  is to be connected to the running system shown in Figure 5–27. The following steps should be taken to accomplish the paralleling.

*First*, using voltmeters, the field current of the oncoming generator should be adjusted until its terminal voltage is equal to the line voltage of the running system.

*Second*, the phase sequence of the oncoming generator must be compared to the phase sequence of the running system. The phase sequence can be checked in a number of different ways. One way is to alternately connect a small induction motor to the terminals of each of the two generators. If the motor rotates in the same direction each time, then the phase sequence is the same for both generators. If the motor rotates in opposite directions, then the phase sequences differ, and two of the conductors on the incoming generator must be reversed.

Another way to check the phase sequence is the *three-light-bulb method*. In this approach, three light bulbs are stretched across the open terminals of the switch connecting the generator to the system as shown in Figure 5–27b. As the phase changes between the two systems, the light bulbs first get bright (large phase difference) and then get dim (small phase difference). *If all three bulbs get bright and dark together, then the systems have the same phase sequence.* If the bulbs brighten in succession, then the systems have the opposite phase sequence, and one of the sequences must be reversed.

Next, the frequency of the oncoming generator is adjusted to be slightly higher than the frequency of the running system. This is done first by watching a frequency meter until the frequencies are close and then by observing changes in phase between the systems. The oncoming generator is adjusted to a slightly higher frequency so that when it is connected, it will come on the line supplying power as a generator, instead of consuming it as a motor would (this point will be explained later).

Once the frequencies are very nearly equal, the voltages in the two systems will change phase with respect to each other very slowly. The phase changes are observed, and when the phase angles are equal, the switch connecting the two systems together is shut.

How can one tell when the two systems are finally in phase? A simple way is to watch the three light bulbs described above in connection with the discussion of phase sequence. When the three light bulbs all go out, the voltage difference across them is zero and the systems are in phase. This simple scheme works, but it is not very accurate. A better approach is to employ a synchroscope. A *synchroscope* is a meter that measures the difference in phase angle between the  $a$  phases of the two systems. The face of a synchroscope is shown in Figure 5–28. The dial shows the phase difference between the two  $a$  phases, with 0 (meaning in phase)

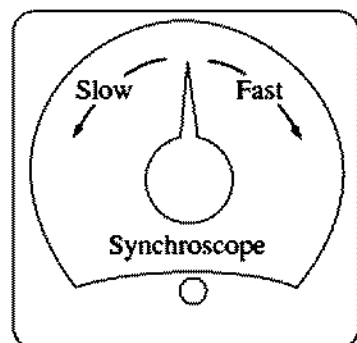

**FIGURE 5-28**  
A synchroscope.

at the top and  $180^\circ$  at the bottom. Since the frequencies of the two systems are slightly different, the phase angle on the meter changes slowly. If the oncoming generator or system is faster than the running system (the desired situation), then the phase angle advances and the synchroscope needle rotates clockwise. If the oncoming machine is slower, the needle rotates counterclockwise. When the synchroscope needle is in the vertical position, the voltages are in phase, and the switch can be shut to connect the systems.

Notice, though, that a *synchroscope checks the relationships on only one phase*. It gives no information about phase sequence.

In large generators belonging to power systems, this whole process of paralleling a new generator to the line is automated, and a computer does this job. For smaller generators, though, the operator manually goes through the paralleling steps just described.

### Frequency–Power and Voltage–Reactive Power Characteristics of a Synchronous Generator

All generators are driven by a *prime mover*, which is the generator's source of mechanical power. The most common type of prime mover is a steam turbine, but other types include diesel engines, gas turbines, water turbines, and even wind turbines.

Regardless of the original power source, all prime movers tend to behave in a similar fashion—as the power drawn from them increases, the speed at which they turn decreases. The decrease in speed is in general nonlinear, but some form of governor mechanism is usually included to make the decrease in speed linear with an increase in power demand.

Whatever governor mechanism is present on a prime mover, it will always be adjusted to provide a slight drooping characteristic with increasing load. The speed droop (SD) of a prime mover is defined by the equation

$$\text{SD} = \frac{n_{nl} - n_{fl}}{n_{fl}} \times 100\% \quad (5-27)$$

where  $n_{nl}$  is the no-load prime-mover speed and  $n_{fl}$  is the full-load prime-mover speed. Most generator prime movers have a speed droop of 2 to 4 percent, as defined in Equation (5-27). In addition, most governors have some type of set point

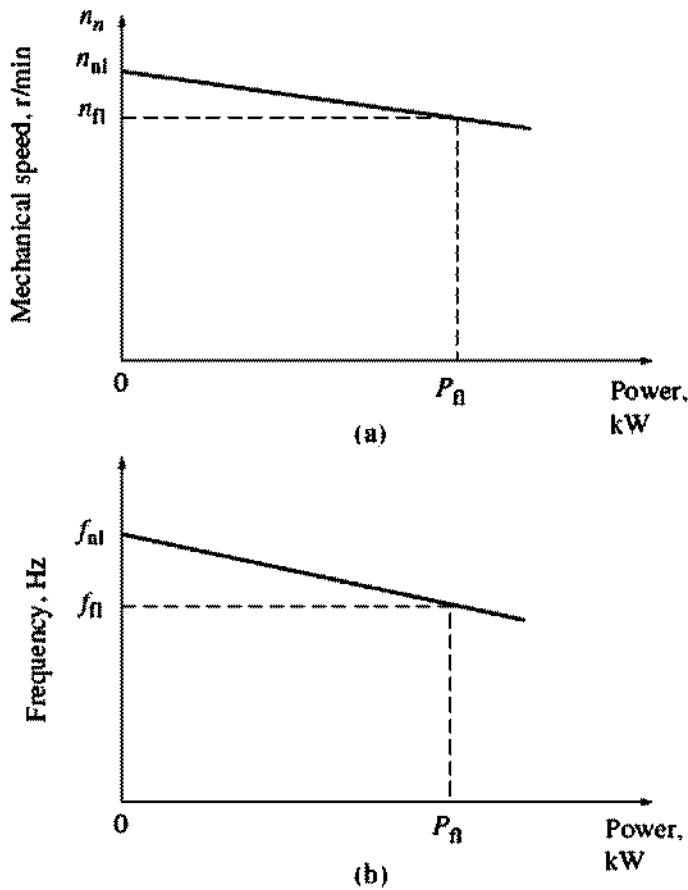
**FIGURE 5-29**

(a) The speed-versus-power curve for a typical prime mover. (b) The resulting frequency-versus-power curve for the generator.

adjustment to allow the no-load speed of the turbine to be varied. A typical speed-versus-power plot is shown in Figure 5-29.

Since the shaft speed is related to the resulting electrical frequency by Equation (4-34),

$$f_e = \frac{n_m P}{120} \quad (4-34)$$

the power output of a synchronous generator is related to its frequency. An example plot of frequency versus power is shown in Figure 5-29b. Frequency-power characteristics of this sort play an essential role in the parallel operation of synchronous generators.

The relationship between frequency and power can be described quantitatively by the equation

$$P = s_p(f_{nl} - f_{sys}) \quad (5-28)$$

where  $P$  = power output of the generator  
 $f_{nl}$  = no-load frequency of the generator  
 $f_{sys}$  = operating frequency of system  
 $s_p$  = slope of curve, in kW/Hz or MW/Hz

A similar relationship can be derived for the reactive power  $Q$  and terminal voltage  $V_T$ . As previously seen, when a lagging load is added to a synchronous

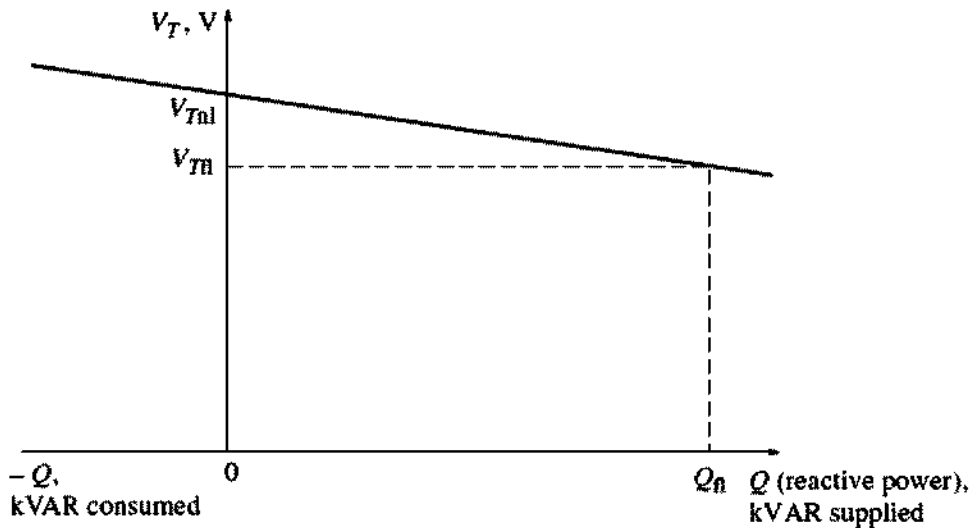

**FIGURE 5-30**

The curve of terminal voltage ( $V_T$ ) versus reactive power ( $Q$ ) for a synchronous generator.

generator, its terminal voltage drops. Likewise, when a leading load is added to a synchronous generator, its terminal voltage increases. It is possible to make a plot of terminal voltage versus reactive power, and such a plot has a drooping characteristic like the one shown in Figure 5-30. This characteristic is not intrinsically linear, but many generator voltage regulators include a feature to make it so. The characteristic curve can be moved up and down by changing the no-load terminal voltage set point on the voltage regulator. As with the frequency-power characteristic, this curve plays an important role in the parallel operation of synchronous generators.

The relationship between the terminal voltage and reactive power can be expressed by an equation similar to the frequency-power relationship [Equation (5-28)] if the voltage regulator produces an output that is linear with changes in reactive power.

It is important to realize that when a single generator is operating alone, the real power  $P$  and reactive power  $Q$  supplied by the generator will be the amount demanded by the load attached to the generator—the  $P$  and  $Q$  supplied cannot be controlled by the generator's controls. Therefore, for any given real power, the governor set points control the generator's operating frequency  $f_e$  and for any given reactive power, the field current controls the generator's terminal voltage  $V_T$ .

**Example 5-5.** Figure 5-31 shows a generator supplying a load. A second load is to be connected in parallel with the first one. The generator has a no-load frequency of 61.0 Hz and a slope  $s_p$  of 1 MW/Hz. Load 1 consumes a real power of 1000 kW at 0.8 PF lagging, while load 2 consumes a real power of 800 kW at 0.707 PF lagging.

- (a) Before the switch is closed, what is the operating frequency of the system?
- (b) After load 2 is connected, what is the operating frequency of the system?
- (c) After load 2 is connected, what action could an operator take to restore the system frequency to 60 Hz?



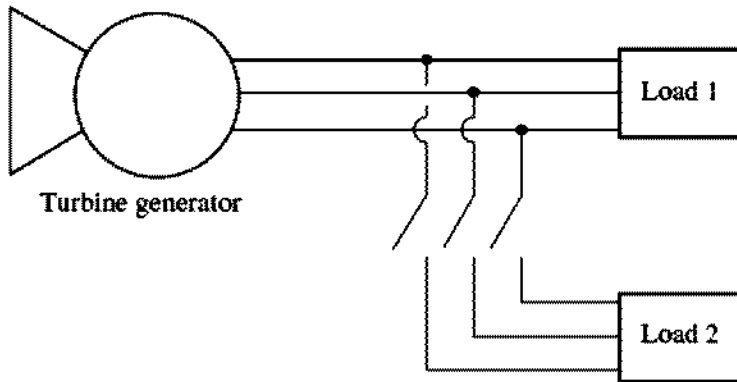

**FIGURE 5-31**  
The power system in Example 5-5.

**Solution**

This problem states that the slope of the generator's characteristic is 1 MW/Hz and that its no-load frequency is 61 Hz. Therefore, the power produced by the generator is given by

$$P = s_p(f_{nl} - f_{sys}) \quad (5-28)$$

so

$$f_{sys} = f_{nl} - \frac{P}{s_p}$$

(a) The initial system frequency is given by

$$\begin{aligned} f_{sys} &= f_{nl} - \frac{P}{s_p} \\ &= 61 \text{ Hz} - \frac{1000 \text{ kW}}{1 \text{ MW/Hz}} = 61 \text{ Hz} - 1 \text{ Hz} = 60 \text{ Hz} \end{aligned}$$

(b) After load 2 is connected,

$$\begin{aligned} f_{sys} &= f_{nl} - \frac{P}{s_p} \\ &= 61 \text{ Hz} - \frac{1800 \text{ kW}}{1 \text{ MW/Hz}} = 61 \text{ Hz} - 1.8 \text{ Hz} = 59.2 \text{ Hz} \end{aligned}$$

(c) After the load is connected, the system frequency falls to 59.2 Hz. To restore the system to its proper operating frequency, the operator should increase the governor no-load set points by 0.8 Hz, to 61.8 Hz. This action will restore the system frequency to 60 Hz.

To summarize, when a generator is operating by itself supplying the system loads, then

1. The real and reactive power supplied by the generator will be the amount demanded by the attached load.
2. The governor set points of the generator will control the operating frequency of the power system.

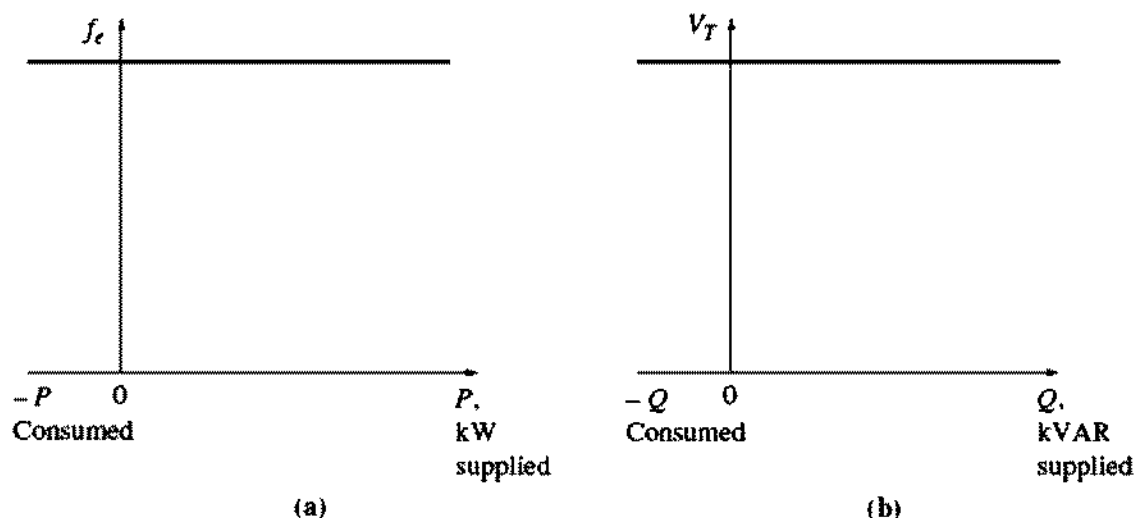

FIGURE 5-32

Curves for an infinite bus: (a) frequency versus power and (b) terminal voltage versus reactive power.

3. The field current (or the field regulator set points) control the terminal voltage of the power system.

This is the situation found in isolated generators in remote field environments.

### Operation of Generators in Parallel with Large Power Systems

When a synchronous generator is connected to a power system, the power system is often so large that *nothing* the operator of the generator does will have much of an effect on the power system. An example of this situation is the connection of a single generator to the U.S. power grid. The U.S. power grid is so large that no reasonable action on the part of the one generator can cause an observable change in overall grid frequency.

This idea is idealized in the concept of an infinite bus. An *infinite bus* is a power system so large that its voltage and frequency do not vary regardless of how much real and reactive power is drawn from or supplied to it. The power–frequency characteristic of such a system is shown in Figure 5-32a, and the reactive power–voltage characteristic is shown in Figure 5-32b.

To understand the behavior of a generator connected to such a large system, examine a system consisting of a generator and an infinite bus in parallel supplying a load. Assume that the generator's prime mover has a governor mechanism, but that the field is controlled manually by a resistor. It is easier to explain generator operation without considering an automatic field current regulator, so this discussion will ignore the slight differences caused by the field regulator when one is present. Such a system is shown in Figure 5-33a.

When a generator is connected in parallel with another generator or a large system, *the frequency and terminal voltage of all the machines must be the same,*

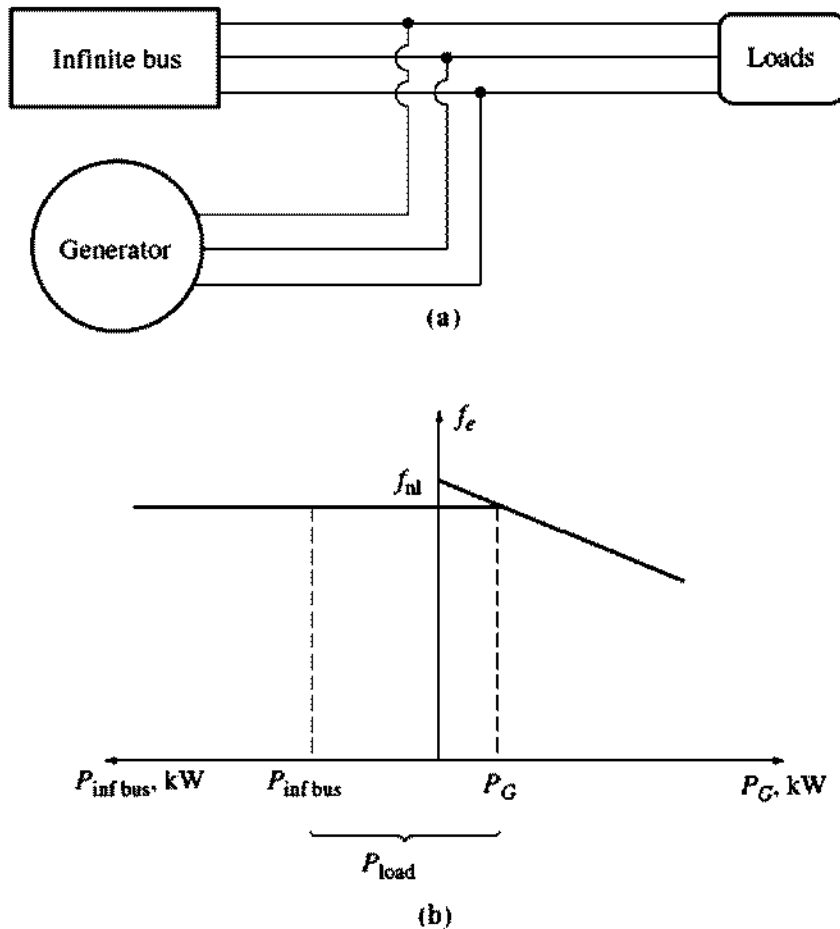
**FIGURE 5-33**

(a) A synchronous generator operating in parallel with an infinite bus. (b) The frequency-versus-power diagram (or *house diagram*) for a synchronous generator in parallel with an infinite bus.

since their output conductors are tied together. Therefore, their real power–frequency and reactive power–voltage characteristics can be plotted back to back, with a common vertical axis. Such a sketch, sometimes informally called a *house diagram*, is shown in Figure 5-33b.

Assume that the generator has just been paralleled with the infinite bus according to the procedure described previously. Then the generator will be essentially “floating” on the line, supplying a small amount of real power and little or no reactive power. This situation is shown in Figure 5-34.

Suppose the generator had been paralleled to the line but, instead of being at a slightly higher frequency than the running system, it was at a slightly lower frequency. In this case, when paralleling is completed, the resulting situation is shown in Figure 5-35. Notice that here the no-load frequency of the generator is less than the system’s operating frequency. At this frequency, the power supplied by the generator is actually negative. In other words, when the generator’s no-load frequency is less than the system’s operating frequency, the generator actually consumes electric power and runs as a motor. It is to ensure that a generator comes on line supplying power instead of consuming it that the oncoming machine’s frequency is adjusted higher than the running system’s frequency. *Many real generators have a*

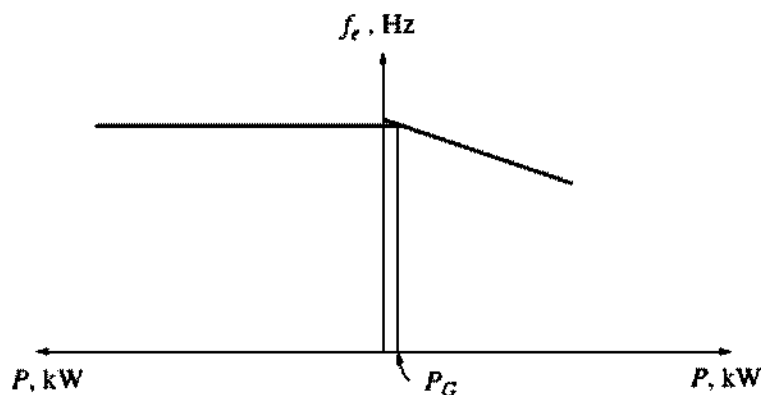

FIGURE 5-34

The frequency-versus-power diagram at the moment just after paralleling.

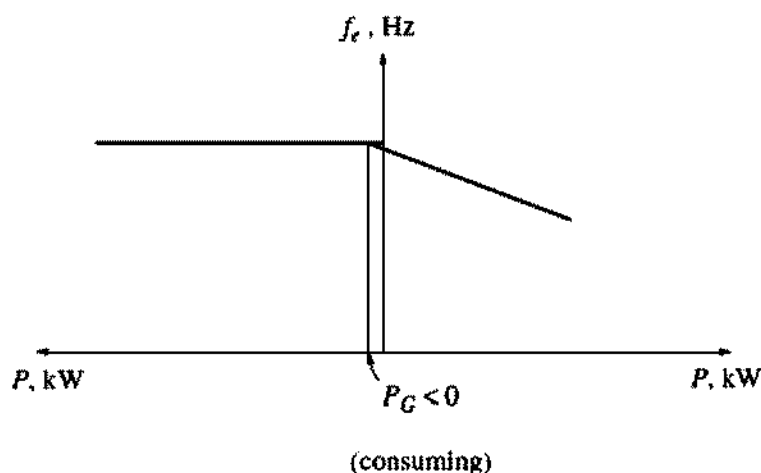
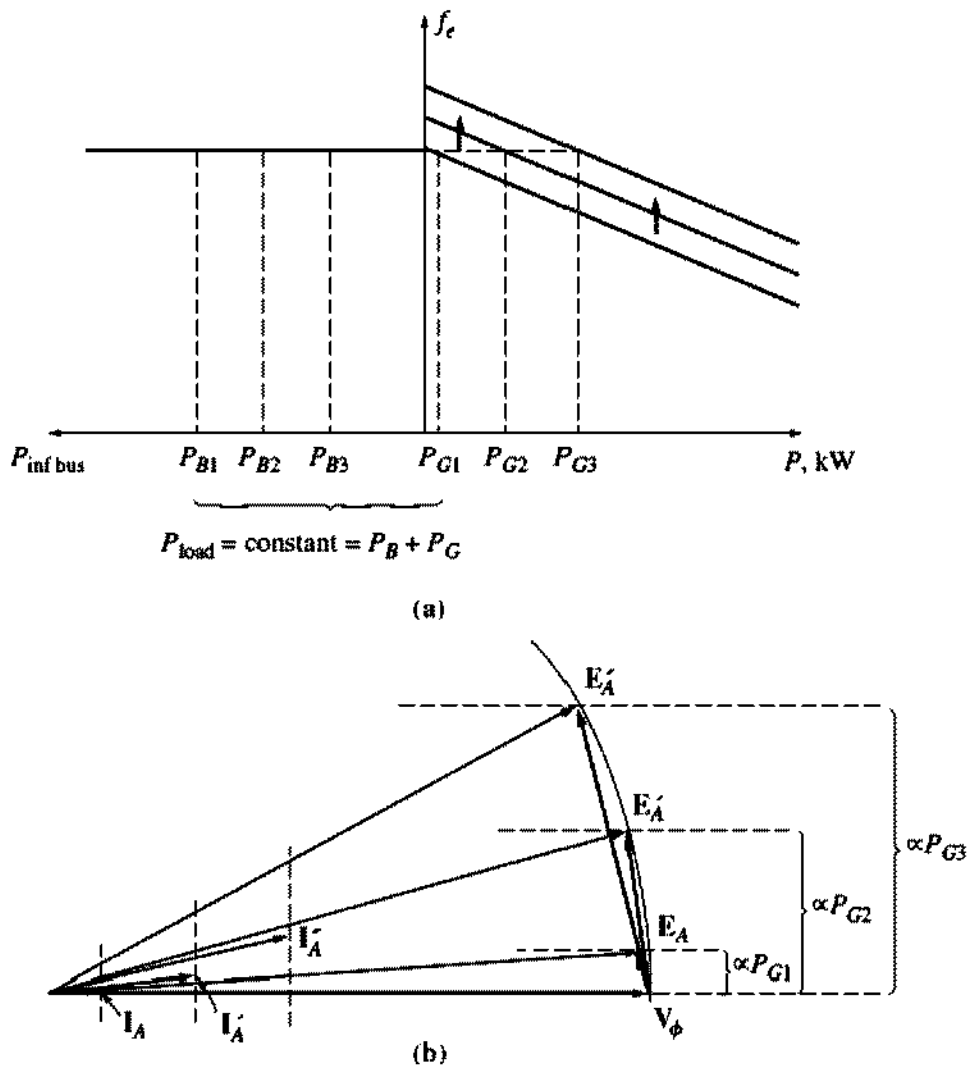

FIGURE 5-35

The frequency-versus-power diagram if the no-load frequency of the generator were slightly less than system frequency before paralleling.

*reverse-power trip connected to them, so it is imperative that they be paralleled with their frequency higher than that of the running system. If such a generator ever starts to consume power, it will be automatically disconnected from the line.*

Once the generator has been connected, what happens when its governor set points are increased? The effect of this increase is to shift the no-load frequency of the generator upward. Since the frequency of the system is unchanged (the frequency of an infinite bus cannot change), the power supplied by the generator increases. This is shown by the house diagram in Figure 5-36a and by the phasor diagram in Figure 5-36b. Notice in the phasor diagram that  $E_A \sin \delta$  (which is proportional to the power supplied as long as  $V_T$  is constant) has increased, while the magnitude of  $E_A (= K\phi\omega)$  remains constant, since both the field current  $I_F$  and the speed of rotation  $\omega$  are unchanged. As the governor set points are further increased, the no-load frequency increases and the power supplied by the generator increases. As the power output increases,  $E_A$  remains at constant magnitude while  $E_A \sin \delta$  is further increased.

**FIGURE 5-36**

The effect of increasing the governor's set points on (a) the house diagram; (b) the phasor diagram.

What happens in this system if the power output of the generator is increased until it exceeds the power consumed by the load? If this occurs, the extra power generated flows back into the infinite bus. The infinite bus, by definition, can supply or consume any amount of power without a change in frequency, so the extra power is consumed.

After the real power of the generator has been adjusted to the desired value, the phasor diagram of the generator looks like Figure 5-36b. Notice that at this time the generator is actually operating at a slightly leading power factor, supplying negative reactive power. Alternatively, the generator can be said to be consuming reactive power. How can the generator be adjusted so that it will supply some reactive power  $Q$  to the system? This can be done by adjusting the field current of the machine. To understand why this is true, it is necessary to consider the constraints on the generator's operation under these circumstances.

The first constraint on the generator is that *the power must remain constant* when  $I_F$  is changed. The power into a generator is given by the equation  $P_{in} = \tau_{ind}\omega_m$ . Now, the prime mover of a synchronous generator has a fixed torque-speed

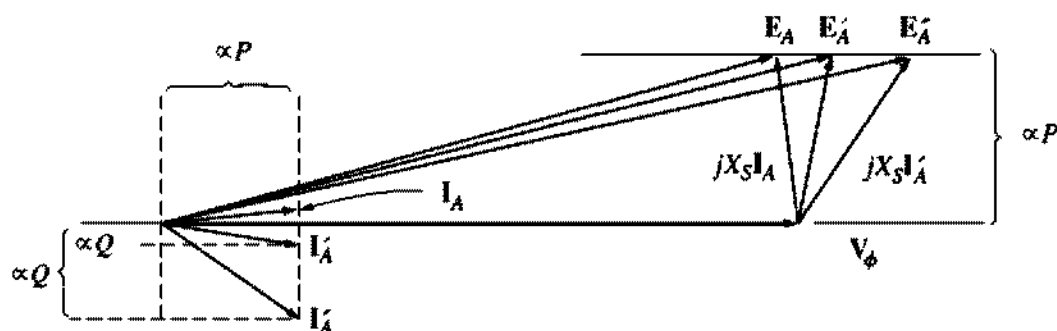

FIGURE 5-37

The effect of increasing the generator's field current on the phasor diagram of the machine.

characteristic for any given governor setting. This curve changes only when the governor set points are changed. Since the generator is tied to an infinite bus, its speed *cannot* change. If the generator's speed does not change and the governor set points have not been changed, the power supplied by the generator must remain constant.

If the power supplied is constant as the field current is changed, then the distances proportional to the power in the phasor diagram ( $I_A \cos \theta$  and  $E_A \sin \delta$ ) cannot change. When the field current is increased, the flux  $\phi$  increases, and therefore  $E_A (= K\phi\omega)$  increases. If  $E_A$  increases, but  $E_A \sin \delta$  must remain constant, then the phasor  $E_A$  must "slide" along the line of constant power, as shown in Figure 5-37. Since  $V_\phi$  is constant, the angle of  $jX_s I_A$  changes as shown, and therefore the angle and magnitude of  $I_A$  change. Notice that as a result the distance proportional to  $Q$  ( $I_A \sin \theta$ ) increases. In other words, *increasing the field current in a synchronous generator operating in parallel with an infinite bus increases the reactive power output of the generator.*

To summarize, when a generator is operating in parallel with an infinite bus:

1. The frequency and terminal voltage of the generator are controlled by the system to which it is connected.
2. The governor set points of the generator control the real power supplied by the generator to the system.
3. The field current in the generator controls the reactive power supplied by the generator to the system.

This situation is much the way real generators operate when connected to a very large power system.

### Operation of Generators in Parallel with Other Generators of the Same Size

When a single generator operated alone, the real and reactive powers ( $P$  and  $Q$ ) supplied by the generator were fixed, constrained to be equal to the power demanded by the load, and the frequency and terminal voltage were varied by the

governor set points and the field current. When a generator operated in parallel with an infinite bus, the frequency and terminal voltage were constrained to be constant by the infinite bus, and the real and reactive powers were varied by the governor set points and the field current. What happens when a synchronous generator is connected in parallel not with an infinite bus, but rather with another generator of the same size? What will be the effect of changing governor set points and field currents?

If a generator is connected in parallel with another one of the same size, the resulting system is as shown in Figure 5–38a. In this system, the basic constraint is that *the sum of the real and reactive powers supplied by the two generators must equal the  $P$  and  $Q$  demanded by the load*. The system frequency is not constrained to be constant, and neither is the power of a given generator constrained to be constant. The power-frequency diagram for such a system immediately after  $G_2$  has been paralleled to the line is shown in Figure 5–38b. Here, the total power  $P_{\text{tot}}$  (which is equal to  $P_{\text{load}}$ ) is given by

$$P_{\text{tot}} = P_{\text{load}} = P_{G_1} + P_{G_2} \quad (5-29a)$$

and the total reactive power is given by

$$Q_{\text{tot}} = Q_{\text{load}} = Q_{G_1} + Q_{G_2} \quad (5-29b)$$

What happens if the governor set points of  $G_2$  are increased? When the governor set points of  $G_2$  are increased, the power-frequency curve of  $G_2$  shifts upward, as shown in Figure 5–38c. Remember, the total power supplied to the load must not change. At the original frequency  $f_1$ , the power supplied by  $G_1$  and  $G_2$  will now be larger than the load demand, so the system cannot continue to operate at the same frequency as before. In fact, there is only one frequency at which the sum of the powers out of the two generators is equal to  $P_{\text{load}}$ . That frequency  $f_2$  is higher than the original system operating frequency. At that frequency,  $G_2$  supplies more power than before, and  $G_1$  supplies less power than before.

Therefore, when two generators are operating together, an increase in governor set points on one of them

1. *Increases the system frequency.*
2. *Increases the power supplied by that generator, while reducing the power supplied by the other one.*

What happens if the field current of  $G_2$  is increased? The resulting behavior is analogous to the real-power situation and is shown in Figure 5–38d. When two generators are operating together and the field current of  $G_2$  is increased,

1. *The system terminal voltage is increased.*
2. *The reactive power  $Q$  supplied by that generator is increased, while the reactive power supplied by the other generator is decreased.*

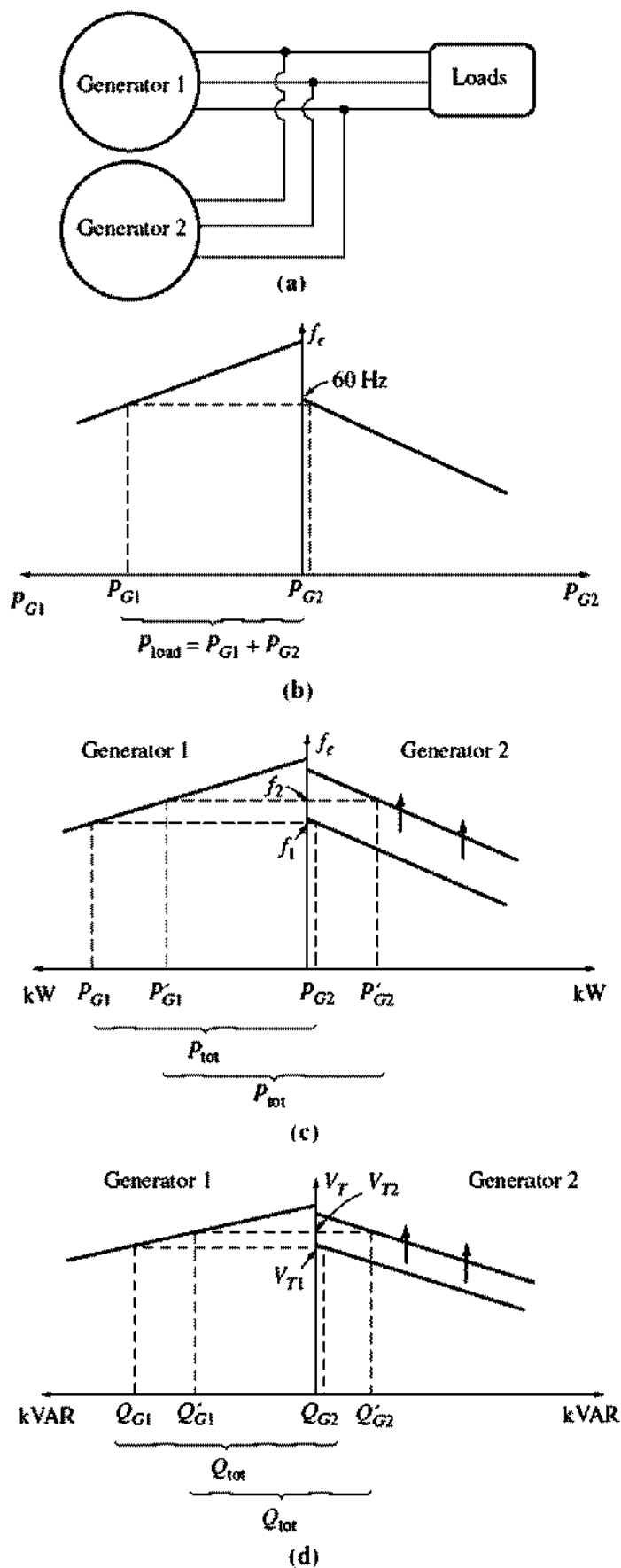

**FIGURE 5-38**

(a) A generator connected in parallel with another machine of the same size. (b) The corresponding house diagram at the moment generator 2 is paralleled with the system. (c) The effect of increasing generator 2's governor set points on the operation of the system. (d) The effect of increasing generator 2's field current on the operation of the system.



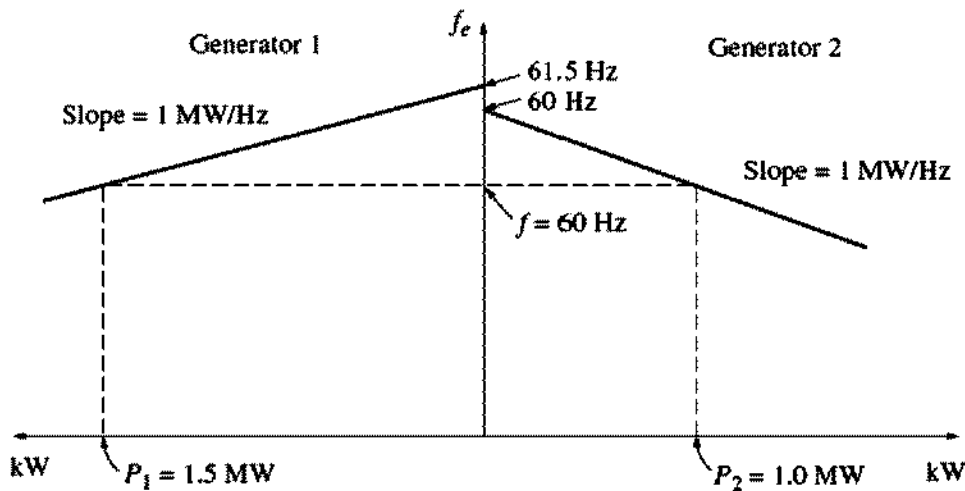

**FIGURE 5-39**  
The house diagram for the system in Example 5-5.

If the slopes and no-load frequencies of the generator's speed droop (frequency–power) curves are known, then the powers supplied by each generator and the resulting system frequency can be determined quantitatively. Example 5-6 shows how this can be done.

**Example 5-6.** Figure 5-38a shows two generators supplying a load. Generator 1 has a no-load frequency of 61.5 Hz and a slope  $s_{p1}$  of 1 MW/Hz. Generator 2 has a no-load frequency of 61.0 Hz and a slope  $s_{p2}$  of 1 MW/Hz. The two generators are supplying a real load totaling 2.5 MW at 0.8 PF lagging. The resulting system power-frequency or house diagram is shown in Figure 5-39.

- At what frequency is this system operating, and how much power is supplied by each of the two generators?
- Suppose an additional 1-MW load were attached to this power system. What would the new system frequency be, and how much power would  $G_1$  and  $G_2$  supply now?
- With the system in the configuration described in part *b*, what will the system frequency and generator powers be if the governor set points on  $G_2$  are increased by 0.5 Hz?

#### **Solution**

The power produced by a synchronous generator with a given slope and no-load frequency is given by Equation (5-28):

$$P_1 = s_{p1}(f_{nl,1} - f_{sys})$$

$$P_2 = s_{p2}(f_{nl,2} - f_{sys})$$

Since the total power supplied by the generators must equal the power consumed by the loads,

$$P_{load} = P_1 + P_2$$

These equations can be used to answer all the questions asked.

- (a) In the first case, both generators have a slope of 1 MW/Hz, and  $G_1$  has a no-load frequency of 61.5 Hz, while  $G_2$  has a no-load frequency of 61.0 Hz. The total load is 2.5 MW. Therefore, the system frequency can be found as follows:

$$\begin{aligned} P_{\text{load}} &= P_1 + P_2 \\ &= s_{P1}(f_{\text{nl},1} - f_{\text{sys}}) + s_{P2}(f_{\text{nl},2} - f_{\text{sys}}) \\ 2.5 \text{ MW} &= (1 \text{ MW/Hz})(61.5 \text{ Hz} - f_{\text{sys}}) + (1 \text{ MW/Hz})(61 \text{ Hz} - f_{\text{sys}}) \\ &= 61.5 \text{ MW} - (1 \text{ MW/Hz})f_{\text{sys}} + 61 \text{ MW} - (1 \text{ MW/Hz})f_{\text{sys}} \\ &= 122.5 \text{ MW} - (2 \text{ MW/Hz})f_{\text{sys}} \end{aligned}$$

$$\text{therefore } f_{\text{sys}} = \frac{122.5 \text{ MW} - 2.5 \text{ MW}}{(2 \text{ MW/Hz})} = 60.0 \text{ Hz}$$

The resulting powers supplied by the two generators are

$$\begin{aligned} P_1 &= s_{P1}(f_{\text{nl},1} - f_{\text{sys}}) \\ &= (1 \text{ MW/Hz})(61.5 \text{ Hz} - 60.0 \text{ Hz}) = 1.5 \text{ MW} \\ P_2 &= s_{P2}(f_{\text{nl},2} - f_{\text{sys}}) \\ &= (1 \text{ MW/Hz})(61.0 \text{ Hz} - 60.0 \text{ Hz}) = 1 \text{ MW} \end{aligned}$$

- (b) When the load is increased by 1 MW, the total load becomes 3.5 MW. The new system frequency is now given by

$$\begin{aligned} P_{\text{load}} &= s_{P1}(f_{\text{nl},1} - f_{\text{sys}}) + s_{P2}(f_{\text{nl},2} - f_{\text{sys}}) \\ 3.5 \text{ MW} &= (1 \text{ MW/Hz})(61.5 \text{ Hz} - f_{\text{sys}}) + (1 \text{ MW/Hz})(61 \text{ Hz} - f_{\text{sys}}) \\ &= 61.5 \text{ MW} - (1 \text{ MW/Hz})f_{\text{sys}} + 61 \text{ MW} - (1 \text{ MW/Hz})f_{\text{sys}} \\ &= 122.5 \text{ MW} - (2 \text{ MW/Hz})f_{\text{sys}} \end{aligned}$$

$$\text{therefore } f_{\text{sys}} = \frac{122.5 \text{ MW} - 3.5 \text{ MW}}{(2 \text{ MW/Hz})} = 59.5 \text{ Hz}$$

The resulting powers are

$$\begin{aligned} P_1 &= s_{P1}(f_{\text{nl},1} - f_{\text{sys}}) \\ &= (1 \text{ MW/Hz})(61.5 \text{ Hz} - 59.5 \text{ Hz}) = 2.0 \text{ MW} \\ P_2 &= s_{P2}(f_{\text{nl},2} - f_{\text{sys}}) \\ &= (1 \text{ MW/Hz})(61.0 \text{ Hz} - 59.5 \text{ Hz}) = 1.5 \text{ MW} \end{aligned}$$

- (c) If the no-load governor set points of  $G_2$  are increased by 0.5 Hz, the new system frequency becomes

$$\begin{aligned} P_{\text{load}} &= s_{P1}(f_{\text{nl},1} - f_{\text{sys}}) + s_{P2}(f_{\text{nl},2} - f_{\text{sys}}) \\ 3.5 \text{ MW} &= (1 \text{ MW/Hz})(61.5 \text{ Hz} - f_{\text{sys}}) + (1 \text{ MW/Hz})(61.5 \text{ Hz} - f_{\text{sys}}) \\ &= 123 \text{ MW} - (2 \text{ MW/Hz})f_{\text{sys}} \\ f_{\text{sys}} &= \frac{123 \text{ MW} - 3.5 \text{ MW}}{(2 \text{ MW/Hz})} = 59.75 \text{ Hz} \end{aligned}$$

The resulting powers are

$$\begin{aligned} P_1 &= P_2 = s_{P1}(f_{\text{nl},1} - f_{\text{sys}}) \\ &= (1 \text{ MW/Hz})(61.5 \text{ Hz} - 59.75 \text{ Hz}) = 1.75 \text{ MW} \end{aligned}$$

Notice that the system frequency rose, the power supplied by  $G_2$  rose, and the power supplied by  $G_1$  fell.

When two generators of similar size are operating in parallel, a change in the governor set points of one of them changes both the system frequency and the power sharing between them. It would normally be desired to adjust only one of these quantities at a time. How can the power sharing of the power system be adjusted independently of the system frequency, and vice versa?

The answer is very simple. An increase in governor set points on one generator increases that machine's power and increases system frequency. A decrease in governor set points on the other generator decreases that machine's power and decreases the system frequency. Therefore, to adjust power sharing without changing the system frequency, *increase the governor set points of one generator and simultaneously decrease the governor set points of the other generator* (see Figure 5-40a). Similarly, *to adjust the system frequency without changing the power sharing, simultaneously increase or decrease both governor set points* (see Figure 5-40b).

Reactive power and terminal voltage adjustments work in an analogous fashion. To shift the reactive power sharing without changing  $V_T$ , *simultaneously increase the field current on one generator and decrease the field current on the other* (see Figure 5-40c). To change the terminal voltage without affecting the reactive power sharing, *simultaneously increase or decrease both field currents* (see Figure 5-40d).

To summarize, in the case of two generators operating together:

1. The system is constrained in that the total power supplied by the two generators together must equal the amount consumed by the load. Neither  $f_{sys}$  nor  $V_T$  is constrained to be constant.
2. To adjust the real power sharing between generators without changing  $f_{sys}$ , simultaneously increase the governor set points on one generator while decreasing the governor set points on the other. The machine whose governor set point was increased will assume more of the load.
3. To adjust  $f_{sys}$  without changing the real power sharing, simultaneously increase or decrease both generators' governor set points.
4. To adjust the reactive power sharing between generators without changing  $V_T$ , simultaneously increase the field current on one generator while decreasing the field current on the other. The machine whose field current was increased will assume more of the reactive load.
5. To adjust  $V_T$  without changing the reactive power sharing, simultaneously increase or decrease both generators' field currents.

It is very important that any synchronous generator intended to operate in parallel with other machines have a *drooping* frequency-power characteristic. If two generators have flat or nearly flat characteristics, then the power sharing between

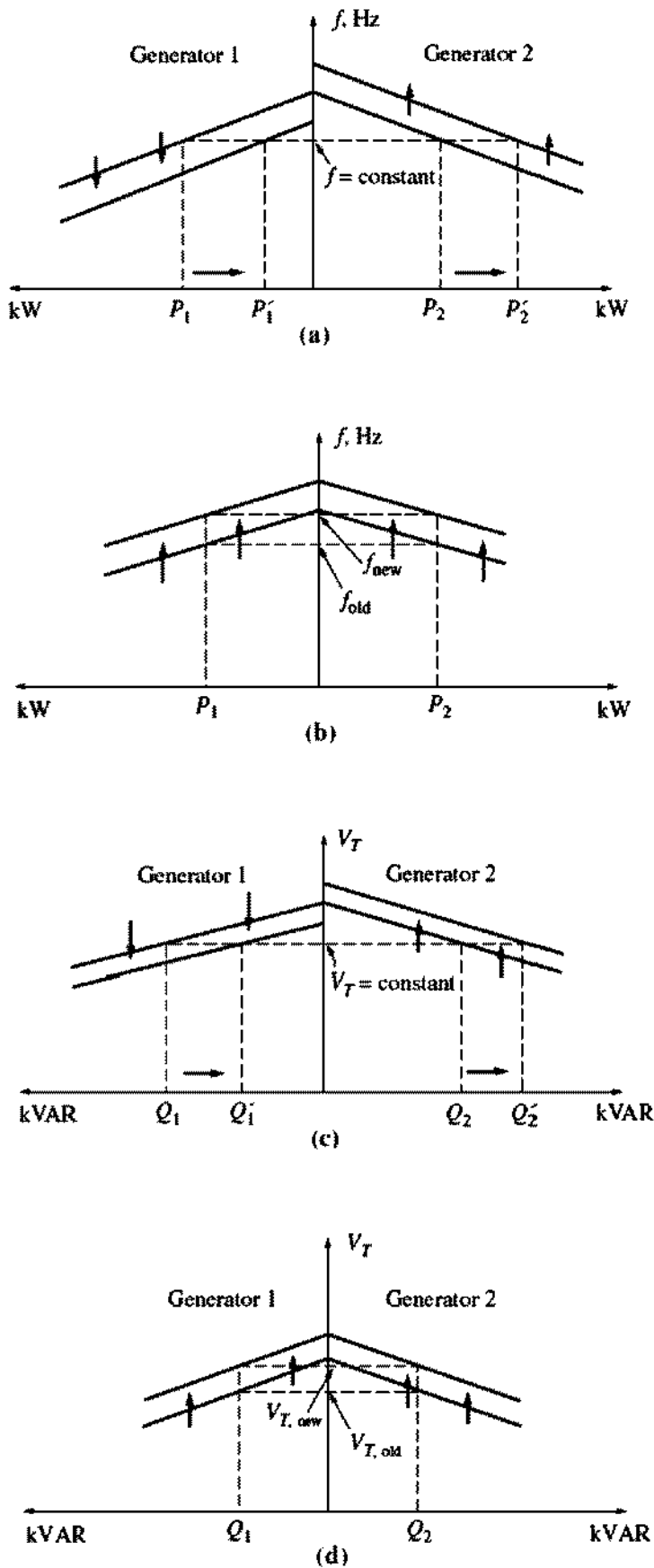

**FIGURE 5-40**

(a) Shifting power sharing without affecting system frequency. (b) Shifting system frequency without affecting power sharing. (c) Shifting reactive power sharing without affecting terminal voltage. (d) Shifting terminal voltage without affecting reactive power sharing.

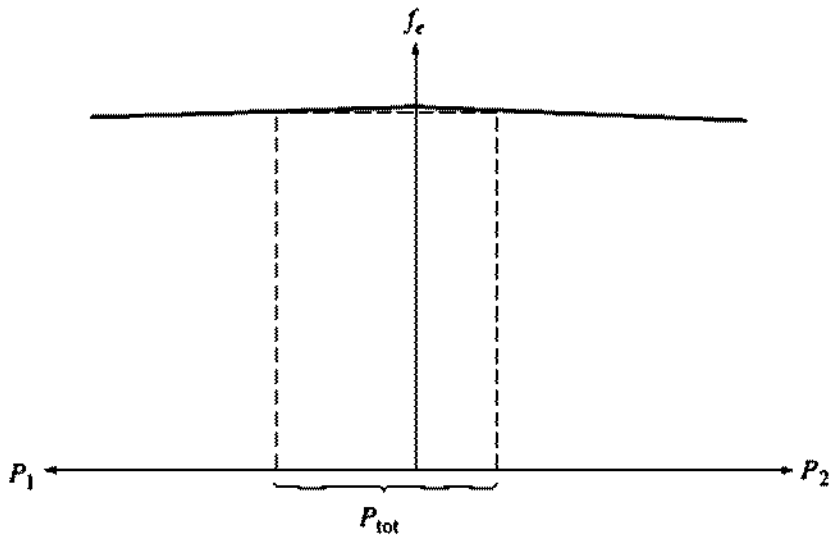
**FIGURE 5-41**

Two synchronous generators with flat frequency–power characteristics. A very tiny change in the no-load frequency of either of these machines could cause huge shifts in the power sharing.

them can vary widely with only the tiniest changes in no-load speed. This problem is illustrated by Figure 5-41. Notice that even very tiny changes in  $f_{nl}$  in one of the generators would cause wild shifts in power sharing. To ensure good control of power sharing between generators, they should have speed droops in the range of 2 to 5 percent.

## 5.10 SYNCHRONOUS GENERATOR TRANSIENTS

When the shaft torque applied to a generator or the output load on a generator changes suddenly, there is always a transient lasting for a finite period of time before the generator returns to steady state. For example, when a synchronous generator is paralleled with a running power system, it is initially turning faster and has a higher frequency than the power system does. Once it is paralleled, there is a transient period before the generator steadies down on the line and runs at line frequency while supplying a small amount of power to the load.

To illustrate this situation, refer to Figure 5-42. Figure 5-42a shows the magnetic fields and the phasor diagram of the generator at the moment just before it is paralleled with the power system. Here, the oncoming generator is supplying no load, its stator current is zero,  $\mathbf{E}_A = \mathbf{V}_\phi$ , and  $\mathbf{B}_R = \mathbf{B}_{net}$ .

At exactly time  $t = 0$ , the switch connecting the generator to the power system is shut, causing a stator current to flow. Since the generator's rotor is still turning faster than the system speed, it continues to move out ahead of the system's voltage  $\mathbf{V}_\phi$ . The induced torque on the shaft of the generator is given by

$$\tau_{ind} = k\mathbf{B}_R \times \mathbf{B}_{net} \quad (4-60)$$

The direction of this torque is opposite to the direction of motion, and it increases as the phase angle between  $\mathbf{B}_R$  and  $\mathbf{B}_{net}$  (or  $\mathbf{E}_A$  and  $\mathbf{V}_\phi$ ) increases. This torque *opposite*

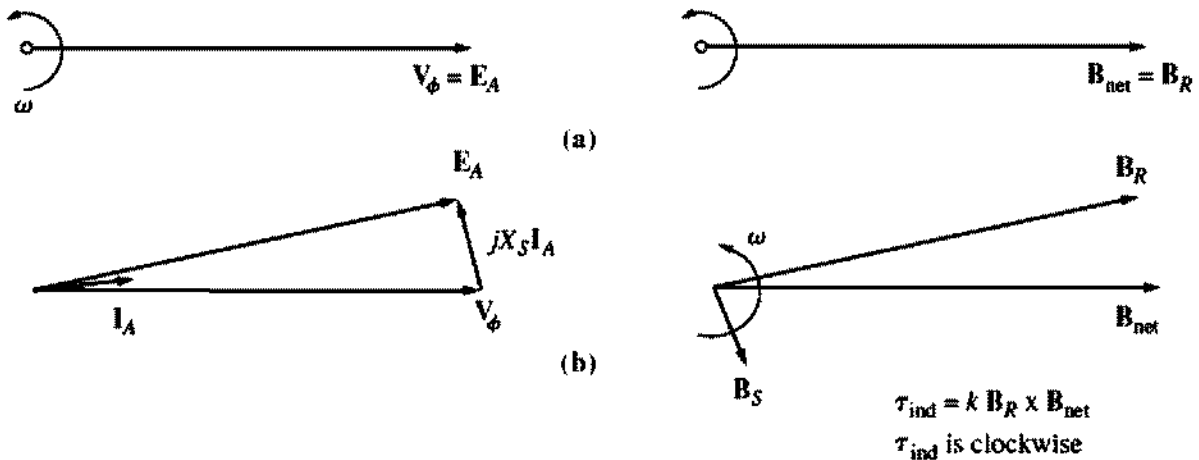

FIGURE 5-42

(a) The phasor diagram and magnetic fields of a generator at the moment of paralleling with a large power system. (b) The phasor diagram and house diagram shortly after a. Here, the rotor has moved on ahead of the net magnetic fields, producing a clockwise torque. This torque is slowing the rotor down to the synchronous speed of the power system.

*the direction of motion* slows down the generator until it finally turns at synchronous speed with the rest of the power system.

Similarly, if the generator were turning at a speed *lower* than synchronous speed when it was paralleled with the power system, then the rotor would fall behind the net magnetic fields, and an induced torque *in the direction of motion* would be induced on the shaft of the machine. This torque would speed up the rotor until it again began turning at synchronous speed.

### Transient Stability of Synchronous Generators

We learned earlier that the static stability limit of a synchronous generator is the maximum power that the generator can supply under any circumstances. The maximum power that the generator can supply is given by Equation (5-21):

$$P_{max} = \frac{3V_\phi E_A}{X_S} \tag{5-21}$$

and the corresponding maximum torque is

$$\tau_{max} = \frac{3V_\phi E_A}{\omega X_S} \tag{5-30}$$

In theory, a generator should be able to supply up to this amount of power and torque before becoming unstable. In practice, however, the maximum load that can be supplied by the generator is limited to a much lower level by its *dynamic stability limit*.

To understand the reason for this limitation, consider the generator in Figure 5-42 again. If the torque applied by the prime mover ( $\tau_{app}$ ) is suddenly increased, the shaft of the generator will begin to speed up, and the torque angle  $\delta$  will increase as described. As the angle  $\delta$  increases, the induced torque  $\tau_{ind}$  of the generator will

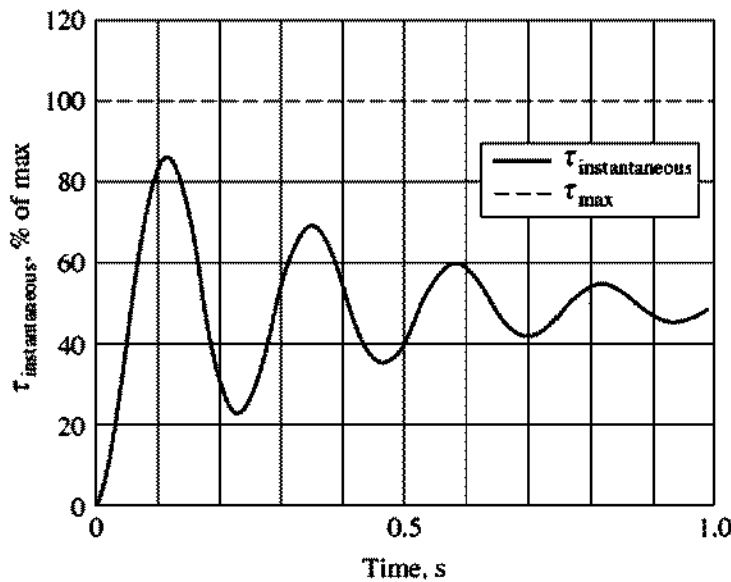

FIGURE 5-43

The dynamic response when an applied torque equal to 50% of  $\tau_{\max}$  is suddenly added to a synchronous generator.

increase until an angle  $\delta$  is reached at which  $\tau_{\text{ind}}$  is equal and opposite to  $\tau_{\text{app}}$ . This is the steady-state operating point of the generator with the new load. However, the rotor of the generator has a great deal of inertia, so its torque angle  $\delta$  actually *overshoots* the steady-state position, and gradually settles out in a damped oscillation, as shown in Figure 5-43. The exact shape of this damped oscillation can be determined by solving a nonlinear differential equation, which is beyond the scope of this book. For more information, see Reference 4, p. 345.

The important point about Figure 5-43 is that *if at any point in the transient response the instantaneous torque exceeds  $\tau_{\max}$ , the synchronous generator will be unstable*. The size of the oscillations depends on how suddenly the additional torque is applied to the synchronous generator. If it is added very gradually, the machine should be able to almost reach the static stability limit. On the other hand, if the load is added sharply, the machine will be stable only up to a much lower limit, which is very complicated to calculate. For very abrupt changes in torque or load, the dynamic stability limit may be less than half of the static stability limit.

### Short-Circuit Transients in Synchronous Generators

By far the severest transient condition that can occur in a synchronous generator is the situation where the three terminals of the generator are suddenly shorted out. Such a short on a power system is called a *fault*. There are several components of current present in a shorted synchronous generator, which will be described below. The same effects occur in less severe transients like load changes, but they are much more obvious in the extreme case of a short circuit.

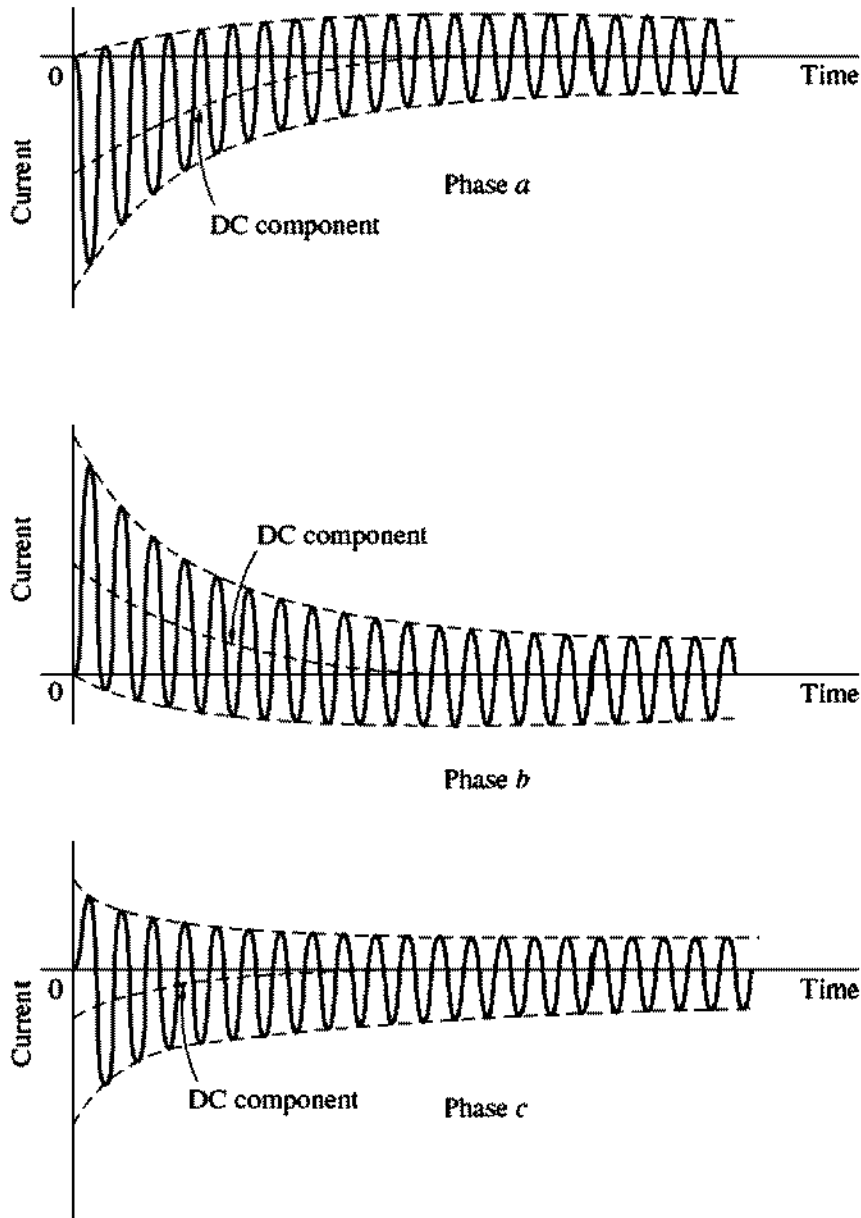

**FIGURE 5-44**

The total fault currents as a function of time during a three-phase fault at the terminals of a synchronous generator.

When a fault occurs on a synchronous generator, the resulting current flow in the phases of the generator can appear as shown in Figure 5-44. The current in each phase shown in Figure 5-42 can be represented as a dc transient component added on top of a symmetrical ac component. The symmetrical ac component by itself is shown in Figure 5-45.

Before the fault, only ac voltages and currents were present within the generator, while after the fault, both ac and dc currents are present. Where did the dc currents come from? Remember that the synchronous generator is basically inductive—it is modeled by an internal generated voltage in series with the synchronous reactance. Also, recall that *a current cannot change instantaneously in an inductor*. When the fault occurs, the ac component of current jumps to a very



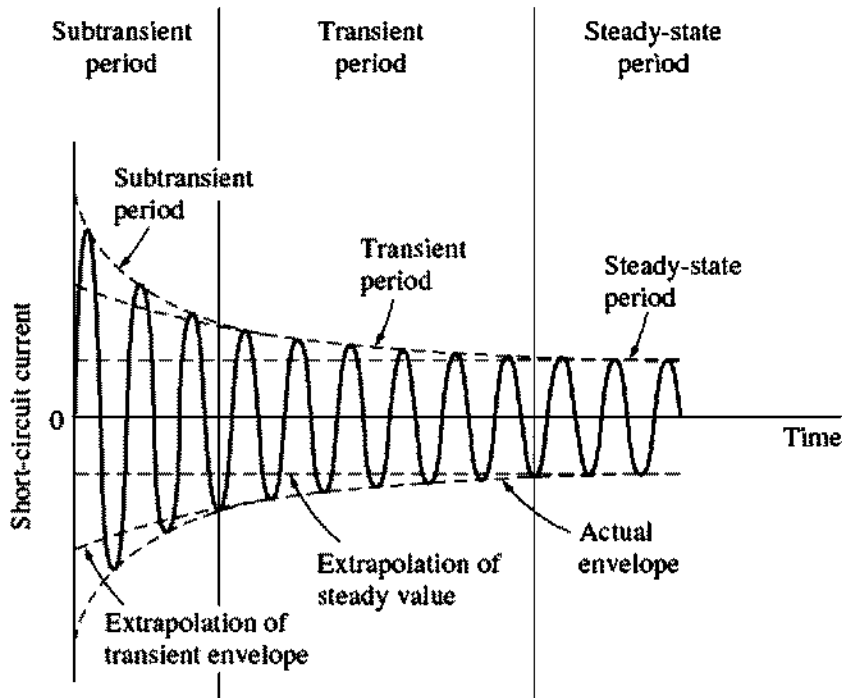

**FIGURE 5-45**  
The symmetric ac component of the fault current.

large value, but the total current cannot change at that instant. The dc component of current is just large enough that the *sum* of the ac and dc components just after the fault equals the ac current flowing just before the fault. Since the instantaneous values of current at the moment of the fault are different in each phase, the magnitude of the dc component of current will be different in each phase.

These dc components of current decay fairly quickly, but they initially average about 50 or 60 percent of the ac current flow the instant after the fault occurs. The total initial current is therefore typically 1.5 or 1.6 times the ac component taken alone.

The ac symmetrical component of current is shown in Figure 5-45. It can be divided into roughly three periods. During the first cycle or so after the fault occurs, the ac current is very large and falls very rapidly. This period of time is called the *subtransient period*. After it is over, the current continues to fall at a slower rate, until at last it reaches a steady state. The period of time during which it falls at a slower rate is called the *transient period*, and the time after it reaches steady state is known as the *steady-state period*.

If the rms magnitude of the ac component of current is plotted as a function of time on a semilogarithmic scale, it is possible to observe the three periods of fault current. Such a plot is shown in Figure 5-46. It is possible to determine the time constants of the decays in each period from such a plot.

The ac rms current flowing in the generator during the subtransient period is called the *subtransient current* and is denoted by the symbol  $I''$ . This current is caused by the damper windings on synchronous generators (see Chapter 6 for a discussion of damper windings). The time constant of the subtransient current is

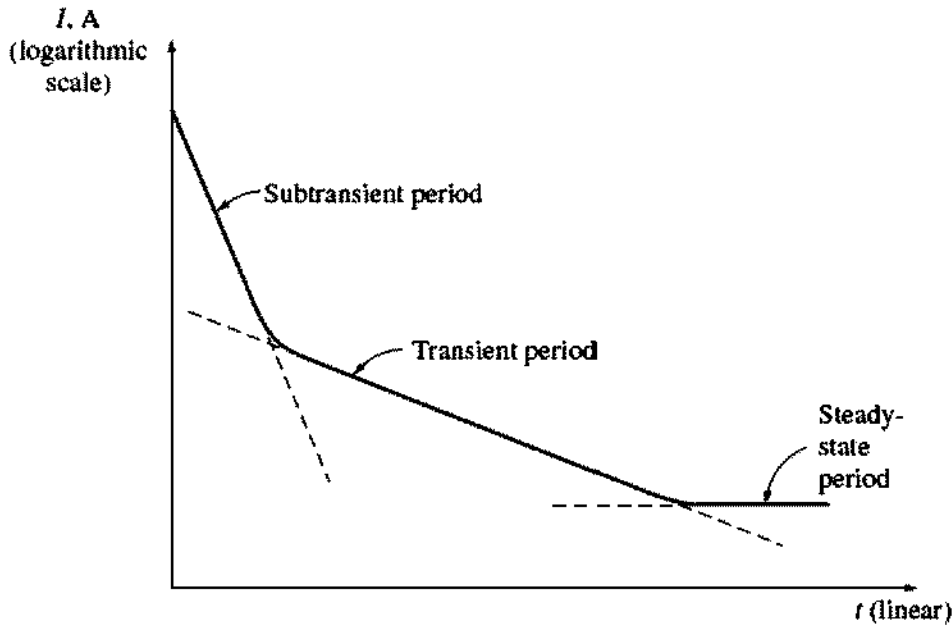

**FIGURE 5-46**

A semilogarithmic plot of the magnitude of the ac component of fault current as a function of time. The subtransient and transient time constants of the generator can be determined from such a plot.

given the symbol  $T''$ , and it can be determined from the slope of the subtransient current in the plot in Figure 5-46. This current can often be 10 times the size of the steady-state fault current.

The rms current flowing in the generator during the transient period is called the *transient current* and is denoted by the symbol  $I'$ . It is caused by a dc component of current induced in *the field circuit* at the time of the short. This field current increases the internal generated voltage and causes an increased fault current. Since the time constant of the dc field circuit is much longer than the time constant of the damper windings, the transient period lasts much longer than the subtransient period. This time constant is given the symbol  $T'$ . The average rms current during the transient period is often as much as 5 times the steady-state fault current.

After the transient period, the fault current reaches a steady-state condition. The steady-state current during a fault is denoted by the symbol  $I_{ss}$ . It is given approximately by the fundamental frequency component of the internal generated voltage  $E_A$  within the machine divided by its synchronous reactance:

$$I_{ss} = \frac{E_A}{X_S} \quad \text{steady state} \quad (5-31)$$

The rms magnitude of the ac fault current in a synchronous generator varies continuously as a function of time. If  $I''$  is the subtransient component of current at the instant of the fault,  $I'$  is the transient component of current at the instant of the fault, and  $I_{ss}$  is the steady-state fault current, then the rms magnitude of the current at any time after a fault occurs at the terminals of the generator is

$$I(t) = (I'' - I')e^{-t/T''} + (I' - I_{ss})e^{-t/T'} + I_{ss} \quad (5-32)$$

It is customary to define subtransient and transient reactances for a synchronous machine as a convenient way to describe the subtransient and transient components of fault current. The *subtransient reactance* of a synchronous generator is defined as the ratio of the fundamental component of the internal generated voltage to the subtransient component of current at the beginning of the fault. It is given by

$$X'' = \frac{E_A}{I''} \quad \text{subtransient} \quad (5-33)$$

Similarly, the *transient reactance* of a synchronous generator is defined as the ratio of the fundamental component of  $E_A$  to the transient component of current  $I'$  at the beginning of the fault. This value of current is found by extrapolating the subtransient region in Figure 5-46 back to time zero:

$$X' = \frac{E_A}{I'} \quad \text{transient} \quad (5-34)$$

For the purposes of sizing protective equipment, the subtransient current is often assumed to be  $E_A/X''$ , and the transient current is assumed to be  $E_A/X'$ , since these are the maximum values that the respective currents take on.

Note that the above discussion of faults assumes that all three phases were shorted out simultaneously. If the fault does not involve all three phases equally, then more complex methods of analysis are required to understand it. These methods (known as symmetrical components) are beyond the scope of this book.

**Example 5-7.** A 100-MVA, 13.5-kV, Y-connected, three-phase, 60-Hz synchronous generator is operating at the rated voltage and no load when a three-phase fault develops at its terminals. Its reactances per unit to the machine's own base are

$$X_s = 1.0 \quad X' = 0.25 \quad X'' = 0.12$$

and its time constants are

$$T' = 1.10\text{s} \quad T'' = 0.04\text{s}$$

The initial dc component in this machine averages 50 percent of the initial ac component.

- (a) What is the ac component of current in this generator the instant after the fault occurs?
- (b) What is the total current (ac plus dc) flowing in the generator right after the fault occurs?
- (c) What will the ac component of the current be after two cycles? After 5 s?

#### **Solution**

The base current of this generator is given by the equation

$$\begin{aligned} I_{L,\text{base}} &= \frac{S_{\text{base}}}{\sqrt{3} V_{L,\text{base}}} & (2-95) \\ &= \frac{100 \text{ MVA}}{\sqrt{3}(13.8 \text{ kV})} = 4184 \text{ A} \end{aligned}$$

The subtransient, transient, and steady-state currents, per unit and in amperes, are

$$I'' = \frac{E_A}{X''} = \frac{1.0}{0.12} = 8.333$$

$$= (8.333)(4184 \text{ A}) = 34,900 \text{ A}$$

$$I' = \frac{E_A}{X'} = \frac{1.0}{0.25} = 4.00$$

$$= (4.00)(4184 \text{ A}) = 16,700 \text{ A}$$

$$I_{ss} = \frac{E_A}{X'} = \frac{1.0}{1.0} = 1.00$$

$$= (1.00)(4184 \text{ A}) = 4184 \text{ A}$$

(a) The initial ac component of current is  $I'' = 34,900 \text{ A}$ .

(b) The total current (ac plus dc) at the beginning of the fault is

$$I_{\text{tot}} = 1.5I'' = 52,350 \text{ A}$$

(c) The ac component of current as a function of time is given by Equation (5-32):

$$I(t) = (I'' - I')e^{-t/T''} + (I' - I_{ss})e^{-t/T'} + I_{ss} \quad (5-32)$$

$$= 18,200e^{-t/0.04 \text{ s}} + 12,516e^{-t/1.1 \text{ s}} + 4184 \text{ A}$$

At two cycles,  $t = 1/30 \text{ s}$ , the total current is

$$I\left(\frac{1}{30}\right) = 7910 \text{ A} + 12,142 \text{ A} + 4184 \text{ A} = 24,236 \text{ A}$$

After two cycles, the transient component of current is clearly the largest one and this time is in the transient period of the short circuit. At 5 s, the current is down to

$$I(5) = 0 \text{ A} + 133 \text{ A} + 4184 \text{ A} = 4317 \text{ A}$$

This is part of the steady-state period of the short circuit.

## 5.11 SYNCHRONOUS GENERATOR RATINGS

There are certain basic limits to the speed and power that may be obtained from a synchronous generator. These limits are expressed as *ratings* on the machine. The purpose of the ratings is to protect the generator from damage due to improper operation. To this end, each machine has a number of ratings listed on a nameplate attached to it.

Typical ratings on a synchronous machine are *voltage*, *frequency*, *speed*, *apparent power (kilovoltamperes)*, *power factor*, *field current*, and *service factor*. These ratings, and the interrelationships among them, will be discussed in the following sections.

### The Voltage, Speed, and Frequency Ratings

The rated frequency of a synchronous generator depends on the power system to which it is connected. The commonly used power system frequencies today are

50 Hz (in Europe, Asia, etc.), 60 Hz (in the Americas), and 400 Hz (in special-purpose and control applications). Once the operating frequency is known, there is only one possible rotational speed for a given number of poles. The fixed relationship between frequency and speed is given by Equation (4-34):

$$f_e = \frac{n_m P}{120} \quad (4-34)$$

as previously described.

Perhaps the most obvious rating is the voltage at which a generator is designed to operate. A generator's voltage depends on the flux, the speed of rotation, and the mechanical construction of the machine. For a given mechanical frame size and speed, the higher the desired voltage, the higher the machine's required flux. However, flux cannot be increased forever, since there is always a maximum allowable field current.

Another consideration in setting the maximum allowable voltage is the breakdown value of the winding insulation—normal operating voltages must not approach breakdown too closely.

Is it possible to operate a generator rated for one frequency at a different frequency? For example, is it possible to operate a 60-Hz generator at 50 Hz? The answer is a *qualified* yes, as long as certain conditions are met. Basically, the problem is that there is a maximum flux achievable in any given machine, and since  $E_A = K\phi\omega$ , the maximum allowable  $E_A$  changes when the speed is changed. Specifically, if a 60-Hz generator is to be operated at 50 Hz, then the operating voltage must be *derated* to 50/60, or 83.3 percent, of its original value. Just the opposite effect happens when a 50-Hz generator is operated at 60 Hz.

## Apparent Power and Power-Factor Ratings

There are two factors that determine the power limits of electric machines. One is the mechanical torque on the shaft of the machine, and the other is the heating of the machine's windings. In all practical synchronous motors and generators, the shaft is strong enough mechanically to handle a much larger steady-state power than the machine is rated for, so the practical steady-state limits are set by heating in the machine's windings.

There are two windings in a synchronous generator, and each one must be protected from overheating. These two windings are the armature winding and the field winding. The maximum acceptable armature current sets the apparent power rating for a generator, since the apparent power  $S$  is given by

$$S = 3V_\phi I_A \quad (5-35)$$

If the rated voltage is known, then the maximum acceptable armature current determines the rated kilovoltamperes of the generator:

$$S_{\text{rated}} = 3V_{\phi,\text{rated}} I_{A,\text{max}} \quad (5-36)$$

or

$$S_{\text{rated}} = \sqrt{3}V_{L,\text{rated}} I_{L,\text{max}} \quad (5-37)$$

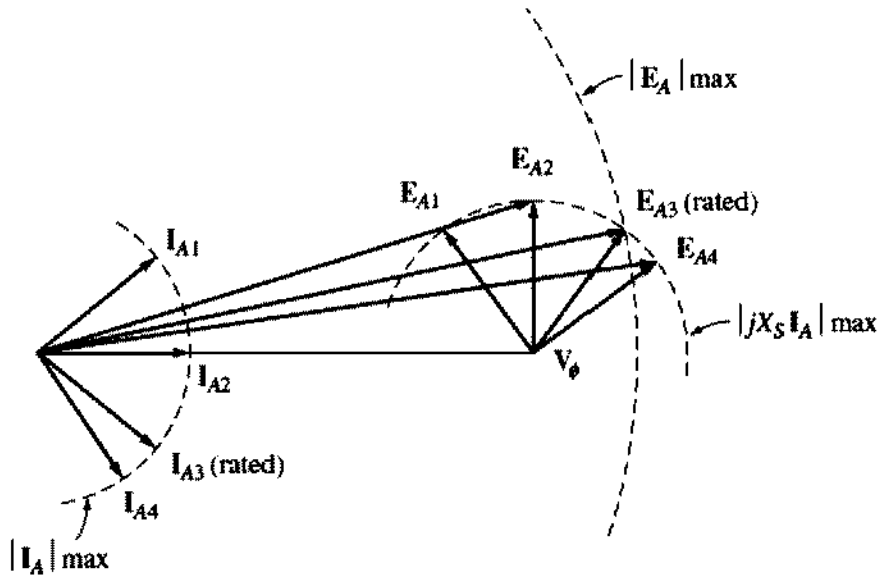

**FIGURE 5-47**  
How the rotor field current limit sets the rated power factor of a generator.

It is important to realize that, for heating the armature windings, *the power factor of the armature current is irrelevant*. The heating effect of the stator copper losses is given by

$$P_{SCL} = 3I_A^2 R_A \quad (5-38)$$

and is independent of the angle of the current with respect to  $V_\phi$ . Because the current angle is irrelevant to the armature heating, these machines are rated in kilovoltamperes instead of kilowatts.

The other winding of concern is the field winding. The field copper losses are given by

$$P_{RCL} = I_F^2 R_F \quad (5-39)$$

so the maximum allowable heating sets a maximum field current for the machine. Since  $E_A = K\phi\omega$  this sets the maximum acceptable size for  $E_A$ .

The effect of having a maximum  $I_F$  and a maximum  $E_A$  translates directly into a restriction on the lowest acceptable power factor of the generator when it is operating at the rated kilovoltamperes. Figure 5-47 shows the phasor diagram of a synchronous generator with the rated voltage and armature current. The current can assume many different angles, as shown. The internal generated voltage  $E_A$  is the sum of  $V_\phi$  and  $jX_S I_A$ . Notice that for some possible current angles the required  $E_A$  exceeds  $E_{A,max}$ . If the generator were operated at the rated armature current and these power factors, the field winding would burn up.

The angle of  $I_A$  that requires the maximum possible  $E_A$  while  $V_\phi$  remains at the rated value gives the rated power factor of the generator. It is possible to operate the generator at a lower (more lagging) power factor than the rated value, but only by cutting back on the kilovoltamperes supplied by the generator.

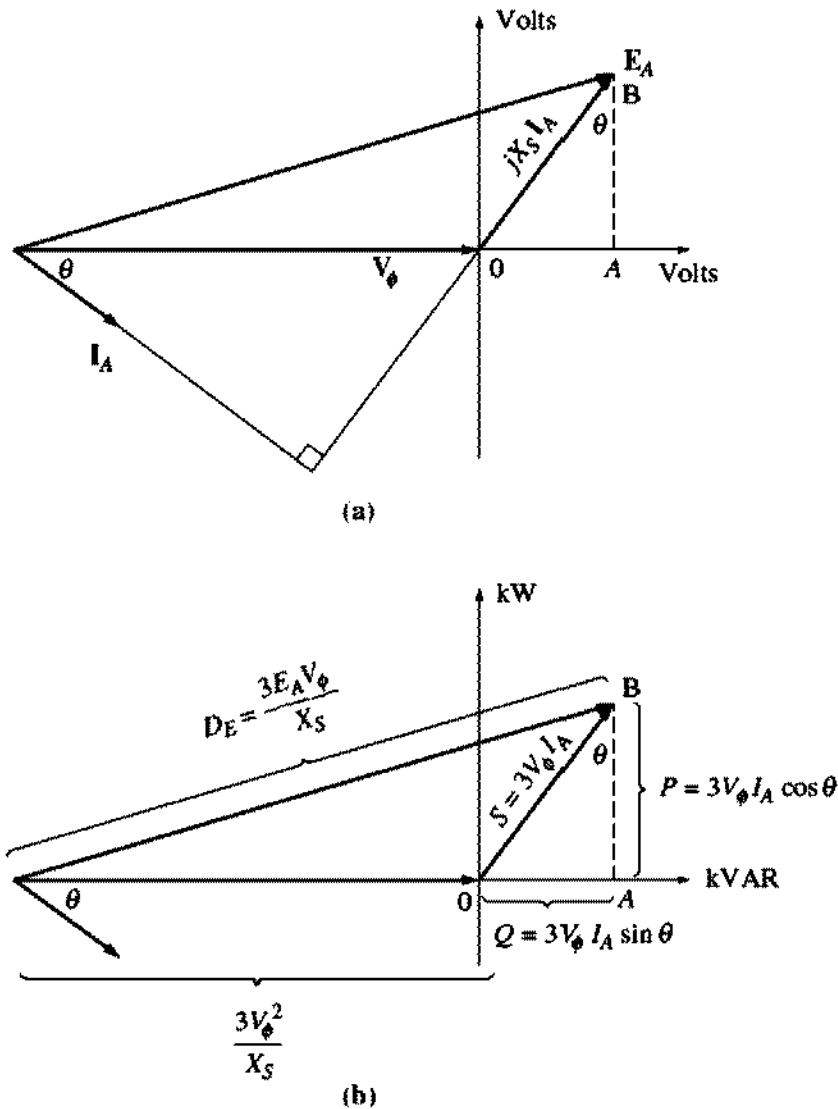
**FIGURE 5-48**

Derivation of a synchronous generator capability curve. (a) The generator phasor diagram; (b) the corresponding power units.

## Synchronous Generator Capability Curves

The stator and rotor heat limits, together with any external limits on a synchronous generator, can be expressed in graphical form by a generator *capability diagram*. A capability diagram is a plot of complex power  $S = P + jQ$ . It is derived from the phasor diagram of the generator, assuming that  $V_\phi$  is constant at the machine's rated voltage.

Figure 5-48a shows the phasor diagram of a synchronous generator operating at a lagging power factor and its rated voltage. An orthogonal set of axes is drawn on the diagram with its origin at the tip of  $V_\phi$  and with units of volts. On this diagram, vertical segment  $AB$  has a length  $X_S I_A \cos \theta$ , and horizontal segment  $OA$  has a length  $X_S I_A \sin \theta$ .

The real power output of the generator is given by

$$P = 3V_\phi I_A \cos \theta \quad (5-17)$$

the reactive power output is given by

$$Q = 3V_\phi I_A \sin \theta \quad (5-19)$$

and the apparent power output is given by

$$S = 3V_\phi I_A \quad (5-35)$$

so the vertical and horizontal axes of this figure can be recalibrated in terms of real and reactive power (Figure 5-48b). The conversion factor needed to change the scale of the axes from volts to voltamperes (power units) is  $3V_\phi/X_S$ :

$$P = 3V_\phi I_A \cos \theta = \frac{3V_\phi}{X_S} (X_S I_A \cos \theta) \quad (5-40)$$

and

$$Q = 3V_\phi I_A \sin \theta = \frac{3V_\phi}{X_S} (X_S I_A \sin \theta) \quad (5-41)$$

On the voltage axes, the origin of the phasor diagram is at  $-V_\phi$  on the horizontal axis, so the origin on the power diagram is at

$$\begin{aligned} Q &= \frac{3V_\phi}{X_S} (-V_\phi) \\ &= -\frac{3V_\phi^2}{X_S} \end{aligned} \quad (5-42)$$

The field current is proportional to the machine's flux, and the flux is proportional to  $E_A = K\phi\omega$ . The length corresponding to  $E_A$  on the power diagram is

$$D_E = -\frac{3E_A V_\phi}{X_S} \quad (5-43)$$

The armature current  $I_A$  is proportional to  $X_S I_A$ , and the length corresponding to  $X_S I_A$  on the power diagram is  $3V_\phi I_A$ .

The final synchronous generator capability curve is shown in Figure 5-49. It is a plot of  $P$  versus  $Q$ , with real power  $P$  on the horizontal axis and reactive power  $Q$  on the vertical axis. Lines of constant armature current  $I_A$  appear as lines of constant  $S = 3V_\phi I_A$ , which are concentric circles around the origin. Lines of constant field current correspond to lines of constant  $E_A$ , which are shown as circles of magnitude  $3E_A V_\phi/X_S$  centered on the point

$$Q = -\frac{3V_\phi^2}{X_S} \quad (5-42)$$

The armature current limit appears as the circle corresponding to the rated  $I_A$  or rated kilovoltamperes, and the field current limit appears as a circle corresponding to the rated  $I_F$  or  $E_A$ . *Any point that lies within both circles is a safe operating point for the generator.*

It is also possible to show other constraints on the diagram, such as the maximum prime-mover power and the static stability limit. A capability curve that also reflects the maximum prime-mover power is shown in Figure 5-50.



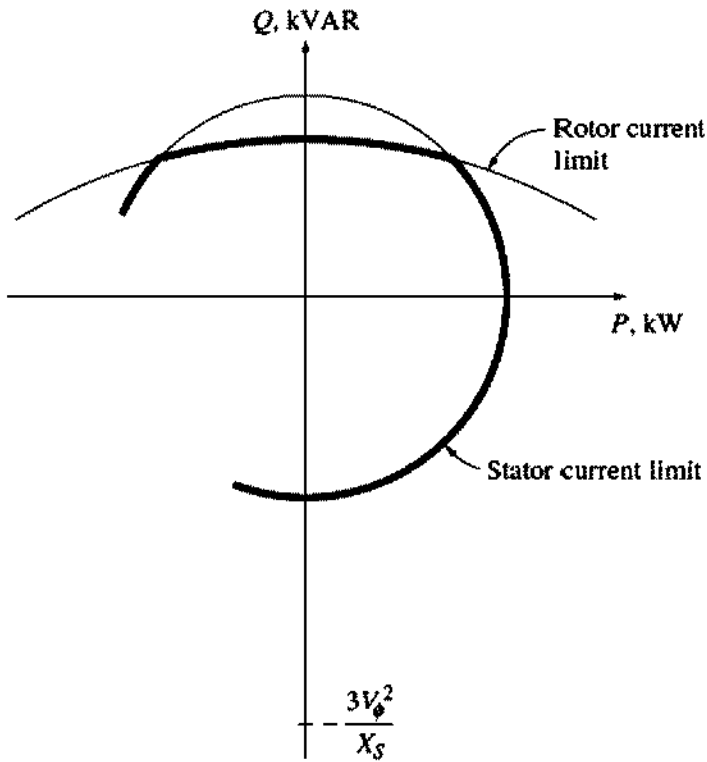

**FIGURE 5-49**  
The resulting generator capability curve.

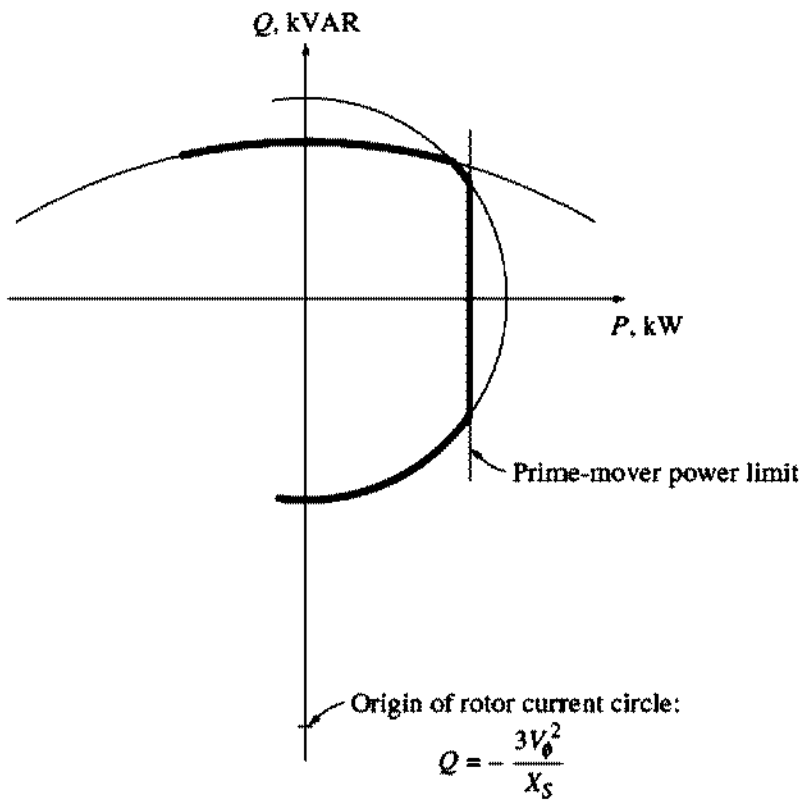

**FIGURE 5-50**  
A capability diagram showing the prime-mover power limit.

**Example 5–8.** A 480-V, 50-Hz, Y-connected, six-pole synchronous generator is rated at 50 kVA at 0.8 PF lagging. It has a synchronous reactance of 1.0  $\Omega$  per phase. Assume that this generator is connected to a steam turbine capable of supplying up to 45 kW. The friction and windage losses are 1.5 kW, and the core losses are 1.0 kW.

- Sketch the capability curve for this generator, including the prime-mover power limit.
- Can this generator supply a line current of 56 A at 0.7 PF lagging? Why or why not?
- What is the maximum amount of reactive power this generator can produce?
- If the generator supplies 30 kW of real power, what is the maximum amount of reactive power that can be simultaneously supplied?

**Solution**

The maximum current in this generator can be found from Equation (5–36):

$$S_{\text{rated}} = 3V_{\phi,\text{rated}} I_{A,\text{max}} \quad (5-36)$$

The voltage  $V_{\phi}$  of this machine is

$$V_{\phi} = \frac{V_T}{\sqrt{3}} = \frac{480 \text{ V}}{\sqrt{3}} = 277 \text{ V}$$

so the maximum armature current is

$$I_{A,\text{max}} = \frac{S_{\text{rated}}}{3V_{\phi}} = \frac{50 \text{ kVA}}{3(277 \text{ V})} = 60 \text{ A}$$

With this information, it is now possible to answer the questions.

- The maximum permissible apparent power is 50 kVA, which specifies the maximum safe armature current. The center of the  $E_A$  circles is at

$$\begin{aligned} Q &= -\frac{3V_{\phi}^2}{X_S} \quad (5-42) \\ &= -\frac{3(277 \text{ V})^2}{1.0 \Omega} = -230 \text{ kVAR} \end{aligned}$$

The maximum size of  $E_A$  is given by

$$\begin{aligned} E_A &= V_{\phi} + jX_S I_A \\ &= 277 \angle 0^\circ \text{ V} + (j1.0 \Omega)(60 \angle -36.87^\circ \text{ A}) \\ &= 313 + j48 \text{ V} = 317 \angle 8.7^\circ \text{ V} \end{aligned}$$

Therefore, the magnitude of the distance proportional to  $E_A$  is

$$\begin{aligned} D_E &= \frac{3E_A V_{\phi}}{X_S} \quad (5-43) \\ &= \frac{3(317 \text{ V})(277 \text{ V})}{1.0 \Omega} = 263 \text{ kVAR} \end{aligned}$$

The maximum output power available with a prime-mover power of 45 kW is approximately

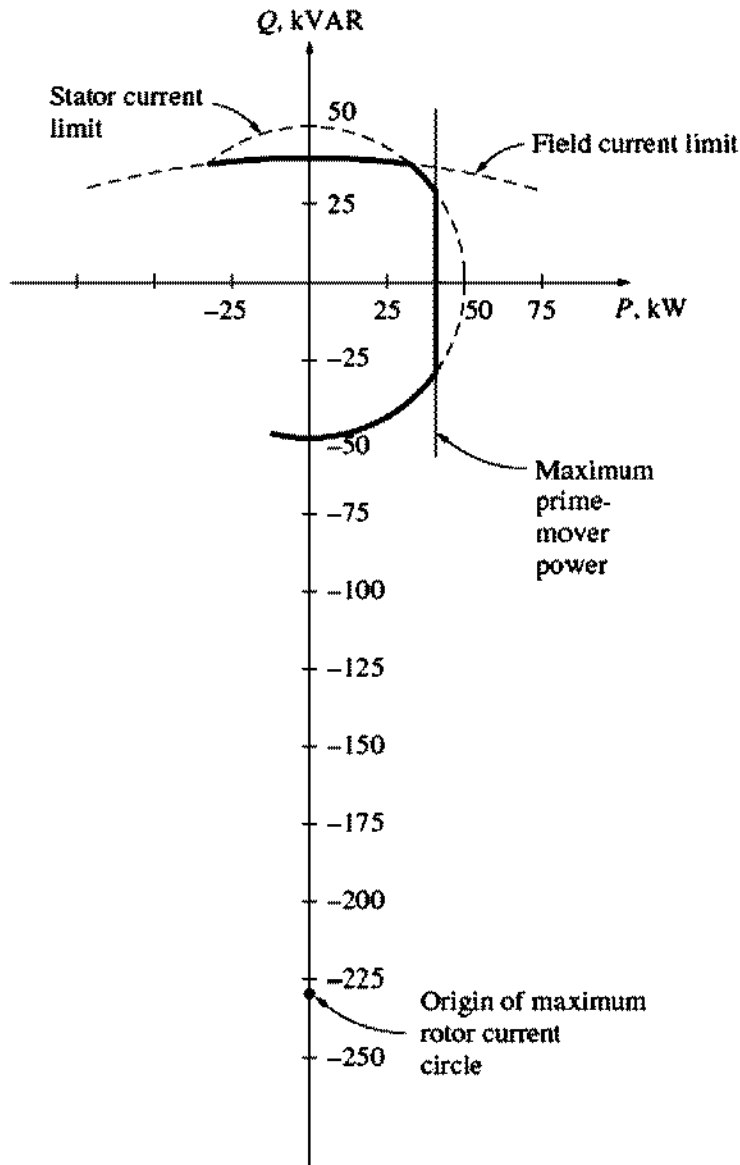

**FIGURE 5-51**  
The capability diagram for the generator in Example 5-8.

$$\begin{aligned}
 P_{\max, \text{out}} &= P_{\max, \text{in}} - P_{\text{mech loss}} - P_{\text{core loss}} \\
 &= 45 \text{ kW} - 1.5 \text{ kW} - 1.0 \text{ kW} = 42.5 \text{ kW}
 \end{aligned}$$

(This value is approximate because the  $I^2R$  loss and the stray load loss were not considered.) The resulting capability diagram is shown in Figure 5-51.

(b) A current of 56 A at 0.7 PF lagging produces a real power of

$$\begin{aligned}
 P &= 3V_{\phi} I_A \cos \theta \\
 &= 3(277 \text{ V})(56 \text{ A})(0.7) = 32.6 \text{ kW}
 \end{aligned}$$

and a reactive power of

$$\begin{aligned}
 Q &= 3V_{\phi} I_A \sin \theta \\
 &= 3(277 \text{ V})(56 \text{ A})(0.714) = 33.2 \text{ kVAR}
 \end{aligned}$$

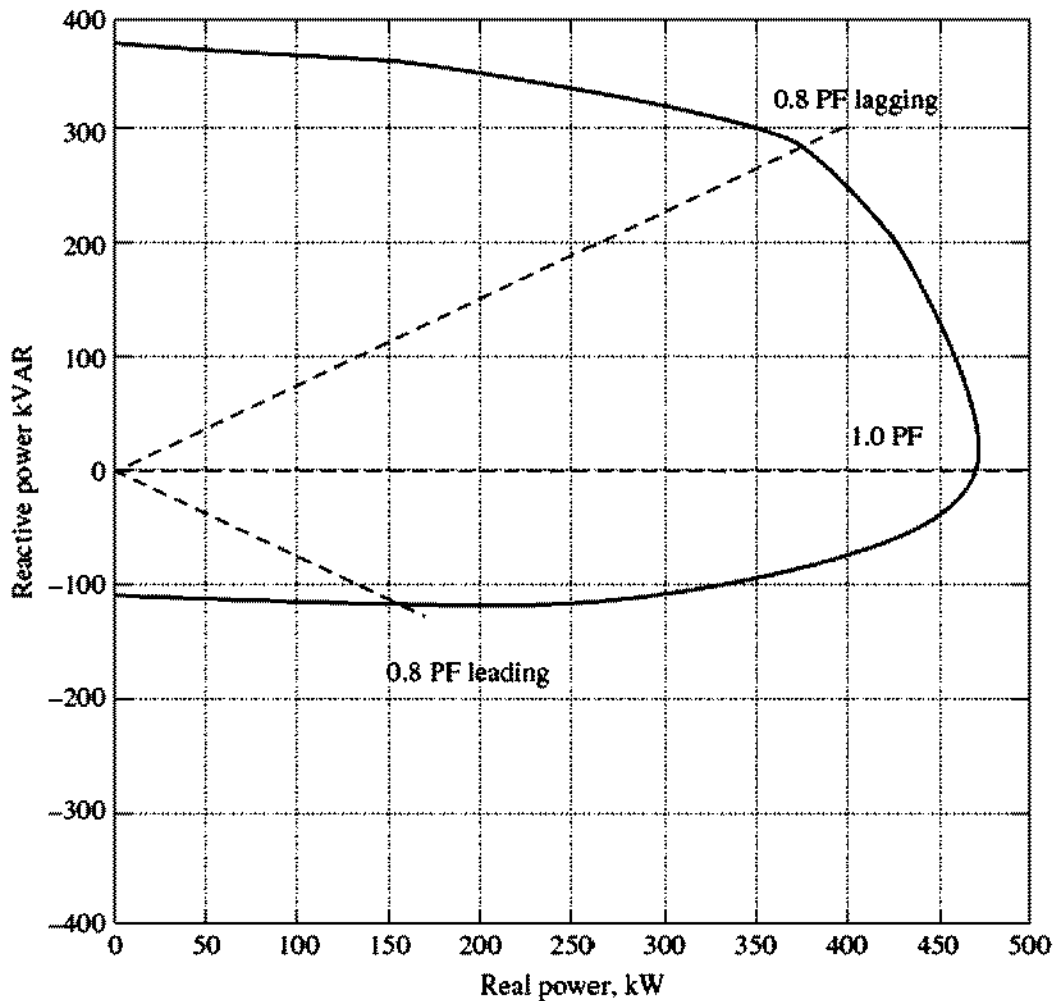

**FIGURE 5-52**

Capability curve for a real synchronous generator rated at 470 kVA. (Courtesy of Marathon Electric Company.)

Plotting this point on the capability diagram shows that it is safely within the maximum  $I_A$  curve but outside the maximum  $I_F$  curve. Therefore, this point is *not* a safe operating condition.

- (c) When the real power supplied by the generator is zero, the reactive power that the generator can supply will be maximum. This point is right at the peak of the capability curve. The  $Q$  that the generator can supply there is

$$Q = 263 \text{ kVAR} - 230 \text{ kVAR} = 33 \text{ kVAR}$$

- (d) If the generator is supplying 30 kW of real power, the maximum reactive power that the generator can supply is 31.5 kVAR. This value can be found by entering the capability diagram at 30 kW and going up the constant-kilowatt line until a limit is reached. The limiting factor in this case is the field current—the armature will be safe up to 39.8 kVAR.

Figure 5-52 shows a typical capability for a real synchronous generator. Note that the capability boundaries are not a perfect circle for a real generator. This is true because real synchronous generators with salient poles have additional effects that we have not modeled. These effects are described in Appendix C.

## Short-Time Operation and Service Factor

The most important limit in the steady-state operation of a synchronous generator is the heating of its armature and field windings. However, the heating limit usually occurs at a point much less than the maximum power that the generator is magnetically and mechanically able to supply. In fact, a typical synchronous generator is often able to supply up to 300 percent of its rated power for a while (until its windings burn up). This ability to supply power above the rated amount is used to supply momentary power surges during motor starting and similar load transients.

It is also possible to use a generator at powers exceeding the rated values for longer periods of time, as long as the windings do not have time to heat up too much before the excess load is removed. For example, a generator that could supply 1 MW indefinitely might be able to supply 1.5 MW for a couple of minutes without serious harm, and for progressively longer periods at lower power levels. However, the load must finally be removed, or the windings will overheat. The higher the power over the rated value, the shorter the time a machine can tolerate it.

Figure 5-53 illustrates this effect. This figure shows the time in seconds required for an overload to cause thermal damage to a typical electrical machine, whose windings were at normal operating temperature before the overload occurred. In this particular machine, a 20 percent overload can be tolerated for 1000 seconds, a 100 percent overload can be tolerated for about 30 seconds, and a 200 percent overload can be tolerated for about 10 seconds before damage occurs.

The maximum temperature rise that a machine can stand depends on the *insulation class* of its windings. There are four standard insulation classes: A, B, F, and H. While there is some variation in acceptable temperature depending on a machine's particular construction and the method of temperature measurement, these classes generally correspond to temperature rises of 60, 80, 105, and 125°C, respectively, above ambient temperature. The higher the insulation class of a given machine, the greater the power that can be drawn out of it without overheating its windings.

Overheating of windings is a *very serious* problem in a motor or generator. It was an old rule of thumb that for each 10°C temperature rise above the rated windings temperature, the average lifetime of a machine is cut in half (see Figure 4-20). Modern insulating materials are less susceptible to breakdown than that, but temperature rises still drastically shorten their lives. For this reason, a synchronous machine should not be overloaded unless absolutely necessary.

A question related to the overheating problem is: Just how well is the power requirement of a machine known? Before installation, there are often only approximate estimates of load. Because of this, general-purpose machines usually have a *service factor*. The service factor is defined as the ratio of the actual maximum power of the machine to its nameplate rating. A generator with a service factor of 1.15 can actually be operated at 115 percent of the rated load indefinitely without harm. The service factor on a machine provides a margin of error in case the loads were improperly estimated.

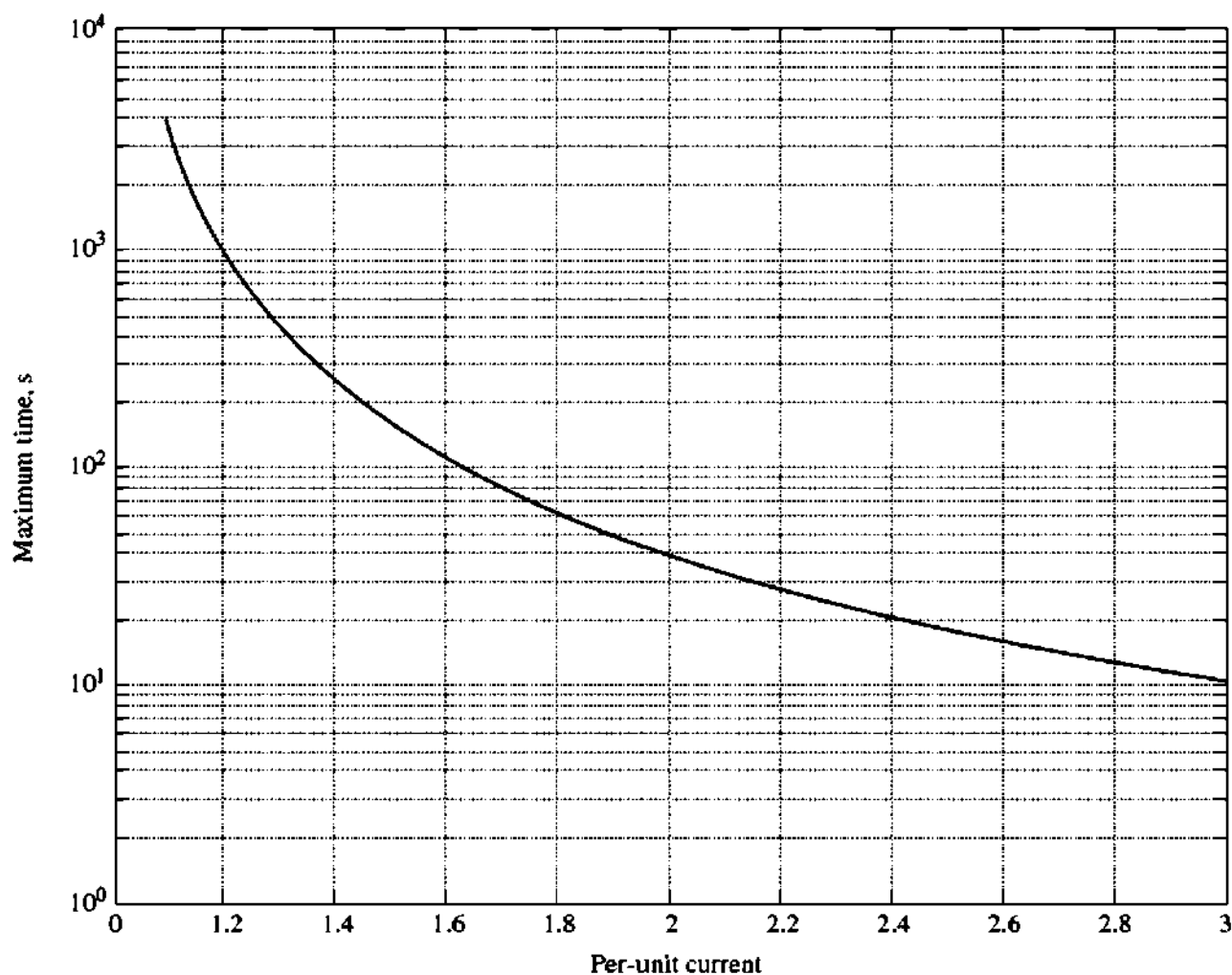

**FIGURE 5-53**

Thermal damage curve for a typical synchronous machine, assuming that the windings were already at operational temperature when the overload is applied. (Courtesy of Marathon Electric Company.)

## 5.12 SUMMARY

A synchronous generator is a device for converting mechanical power from a prime mover to ac electric power at a specific voltage and frequency. The term *synchronous* refers to the fact that this machine's electrical frequency is locked in or synchronized with its mechanical rate of shaft rotation. The synchronous generator is used to produce the vast majority of electric power used throughout the world.

The internal generated voltage of this machine depends on the rate of shaft rotation and on the magnitude of the field flux. The phase voltage of the machine differs from the internal generated voltage by the effects of armature reaction in the generator and also by the internal resistance and reactance of the armature windings. The terminal voltage of the generator will either equal the phase voltage or be related to it by  $\sqrt{3}$ , depending on whether the machine is  $\Delta$ - or Y-connected.

The way in which a synchronous generator operates in a real power system depends on the constraints on it. When a generator operates alone, the real and

reactive powers that must be supplied are determined by the load attached to it, and the governor set points and field current control the frequency and terminal voltage, respectively. When the generator is connected to an infinite bus, its frequency and voltage are fixed, so the governor set points and field current control the real and reactive power flow from the generator. In real systems containing generators of approximately equal size, the governor set points affect both frequency and power flow, and the field current affects both terminal voltage and reactive power flow.

A synchronous generator's ability to produce electric power is primarily limited by heating within the machine. When the generator's windings overheat, the life of the machine can be severely shortened. Since there are two different windings (armature and field), there are two separate constraints on the generator. The maximum allowable heating in the armature windings sets the maximum kilovoltamperes allowable from the machine, and the maximum allowable heating in the field windings sets the maximum size of  $E_A$ . The maximum size of  $E_A$  and the maximum size of  $I_A$  together set the rated power factor of the generator.

## QUESTIONS

- 5-1. Why is the frequency of a synchronous generator locked into its rate of shaft rotation?
- 5-2. Why does an alternator's voltage drop sharply when it is loaded down with a lagging load?
- 5-3. Why does an alternator's voltage rise when it is loaded down with a leading load?
- 5-4. Sketch the phasor diagrams and magnetic field relationships for a synchronous generator operating at (a) unity power factor, (b) lagging power factor, (c) leading power factor.
- 5-5. Explain just how the synchronous impedance and armature resistance can be determined in a synchronous generator.
- 5-6. Why must a 60-Hz generator be derated if it is to be operated at 50 Hz? How much derating must be done?
- 5-7. Would you expect a 400-Hz generator to be larger or smaller than a 60-Hz generator of the same power and voltage rating? Why?
- 5-8. What conditions are necessary for paralleling two synchronous generators?
- 5-9. Why must the oncoming generator on a power system be paralleled at a higher frequency than that of the running system?
- 5-10. What is an infinite bus? What constraints does it impose on a generator paralleled with it?
- 5-11. How can the real power sharing between two generators be controlled without affecting the system's frequency? How can the reactive power sharing between two generators be controlled without affecting the system's terminal voltage?
- 5-12. How can the system frequency of a large power system be adjusted without affecting the power sharing among the system's generators?
- 5-13. How can the concepts of Section 5.9 be expanded to calculate the system frequency and power sharing among three or more generators operating in parallel?
- 5-14. Why is overheating such a serious matter for a generator?

- 5-15. Explain in detail the concept behind capability curves.  
 5-16. What are short-time ratings? Why are they important in regular generator operation?

## PROBLEMS

- 5-1. At a location in Europe, it is necessary to supply 300 kW of 60-Hz power. The only power sources available operate at 50 Hz. It is decided to generate the power by means of a motor-generator set consisting of a synchronous motor driving a synchronous generator. How many poles should each of the two machines have in order to convert 50-Hz power to 60-Hz power?
- 5-2. A 2300-V, 1000-kVA, 0.8-PF-lagging, 60-Hz, two-pole, Y-connected synchronous generator has a synchronous reactance of  $1.1 \Omega$  and an armature resistance of  $0.15 \Omega$ . At 60 Hz, its friction and windage losses are 24 kW, and its core losses are 18 kW. The field circuit has a dc voltage of 200 V, and the maximum  $I_f$  is 10 A. The resistance of the field circuit is adjustable over the range from 20 to 200  $\Omega$ . The OCC of this generator is shown in Figure P5-1.

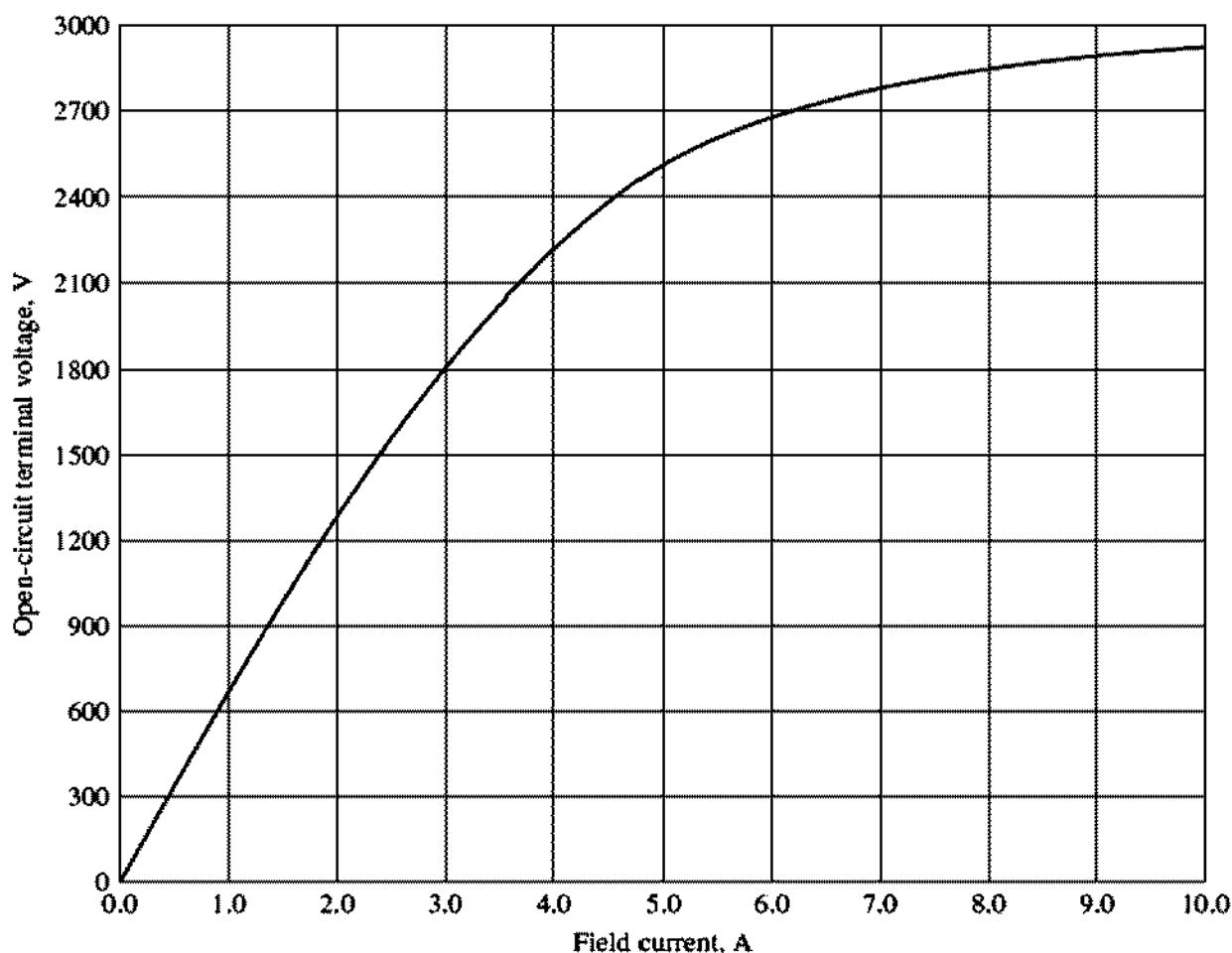

**FIGURE P5-1**

The open-circuit characteristic for the generator in Problem 5-2.

- (a) How much field current is required to make  $V_T$  equal to 2300 V when the generator is running at no load?  
 (b) What is the internal generated voltage of this machine at rated conditions?



- (c) How much field current is required to make  $V_T$  equal to 2300 V when the generator is running at rated conditions?
- (d) How much power and torque must the generator's prime mover be capable of supplying?
- (e) Construct a capability curve for this generator.
- 5-3. Assume that the field current of the generator in Problem 5-2 has been adjusted to a value of 4.5 A.
- (a) What will the terminal voltage of this generator be if it is connected to a  $\Delta$ -connected load with an impedance of  $20 \angle 30^\circ \Omega$ ?
- (b) Sketch the phasor diagram of this generator.
- (c) What is the efficiency of the generator at these conditions?
- (d) Now assume that another identical  $\Delta$ -connected load is to be paralleled with the first one. What happens to the phasor diagram for the generator?
- (e) What is the new terminal voltage after the load has been added?
- (f) What must be done to restore the terminal voltage to its original value?
- 5-4. Assume that the field current of the generator in Problem 5-2 is adjusted to achieve rated voltage (2300 V) at full-load conditions in each of the questions below.
- (a) What is the efficiency of the generator at rated load?
- (b) What is the voltage regulation of the generator if it is loaded to rated kilovoltamperes with 0.8-PF-lagging loads?
- (c) What is the voltage regulation of the generator if it is loaded to rated kilovoltamperes with 0.8-PF-leading loads?
- (d) What is the voltage regulation of the generator if it is loaded to rated kilovoltamperes with unity power factor loads?
- (e) Use MATLAB to plot the terminal voltage of the generator as a function of load for all three power factors.
- 5-5. Assume that the field current of the generator in Problem 5-2 has been adjusted so that it supplies rated voltage when loaded with rated current at unity power factor.
- (a) What is the torque angle  $\delta$  of the generator when supplying rated current at unity power factor?
- (b) When this generator is running at full load with unity power factor, how close is it to the static stability limit of the machine?
- 5-6. A 480-V, 400-kVA, 0.85-PF-lagging, 50-Hz, four-pole,  $\Delta$ -connected generator is driven by a 500-hp diesel engine and is used as a standby or emergency generator. This machine can also be paralleled with the normal power supply (a very large power system) if desired.
- (a) What are the conditions required for paralleling the emergency generator with the existing power system? What is the generator's rate of shaft rotation after paralleling occurs?
- (b) If the generator is connected to the power system and is initially floating on the line, sketch the resulting magnetic fields and phasor diagram.
- (c) The governor setting on the diesel is now increased. Show both by means of house diagrams and by means of phasor diagrams what happens to the generator. How much reactive power does the generator supply now?
- (d) With the diesel generator now supplying real power to the power system, what happens to the generator as its field current is increased and decreased? Show this behavior both with phasor diagrams and with house diagrams.
- 5-7. A 13.8-kV, 10-MVA, 0.8-PF-lagging, 60-Hz, two-pole, Y-connected steam-turbine generator has a synchronous reactance of  $12 \Omega$  per phase and an armature resistance

of  $1.5 \Omega$  per phase. This generator is operating in parallel with a large power system (infinite bus).

- What is the magnitude of  $E_A$  at rated conditions?
- What is the torque angle of the generator at rated conditions?
- If the field current is constant, what is the maximum power possible out of this generator? How much reserve power or torque does this generator have at full load?
- At the absolute maximum power possible, how much reactive power will this generator be supplying or consuming? Sketch the corresponding phasor diagram. (Assume  $I_F$  is still unchanged.)

**5-8.** A 480-V, 100-kW, two-pole, three-phase, 60-Hz synchronous generator's prime mover has a no-load speed of 3630 r/min and a full-load speed of 3570 r/min. It is operating in parallel with a 480-V, 75-kW, four-pole, 60-Hz synchronous generator whose prime mover has a no-load speed of 1800 r/min and a full-load speed of 1785 r/min. The loads supplied by the two generators consist of 100 kW at 0.85 PF lagging.

- Calculate the speed droops of generator 1 and generator 2.
- Find the operating frequency of the power system.
- Find the power being supplied by each of the generators in this system.
- If  $V_T$  is 460 V, what must the generator's operators do to correct for the low terminal voltage?

**5-9.** Three physically identical synchronous generators are operating in parallel. They are all rated for a full load of 3 MW at 0.8 PF lagging. The no-load frequency of generator A is 61 Hz, and its speed droop is 3.4 percent. The no-load frequency of generator B is 61.5 Hz, and its speed droop is 3 percent. The no-load frequency of generator C is 60.5 Hz, and its speed droop is 2.6 percent.

- If a total load consisting of 7 MW is being supplied by this power system, what will the system frequency be and how will the power be shared among the three generators?
- Create a plot showing the power supplied by each generator as a function of the total power supplied to all loads (you may use MATLAB to create this plot). At what load does one of the generators exceed its ratings? Which generator exceeds its ratings first?
- Is this power sharing in *a* acceptable? Why or why not?
- What actions could an operator take to improve the real power sharing among these generators?

**5-10.** A paper mill has installed three steam generators (boilers) to provide process steam and also to use some its waste products as an energy source. Since there is extra capacity, the mill has installed three 5-MW turbine generators to take advantage of the situation. Each generator is a 4160-V, 6250-kVA, 0.85-PF-lagging, two-pole, Y-connected synchronous generator with a synchronous reactance of  $0.75 \Omega$  and an armature resistance of  $0.04 \Omega$ . Generators 1 and 2 have a characteristic power-frequency slope  $s_p$  of 2.5 MW/Hz, and generators 2 and 3 have a slope of 3 MW/Hz.

- If the no-load frequency of each of the three generators is adjusted to 61 Hz, how much power will the three machines be supplying when actual system frequency is 60 Hz?
- What is the maximum power the three generators can supply in this condition without the ratings of one of them being exceeded? At what frequency does this limit occur? How much power does each generator supply at that point?

- (c) What would have to be done to get all three generators to supply their rated real and reactive powers at an overall operating frequency of 60 Hz?
- (d) What would the internal generated voltages of the three generators be under this condition?

Problems 5-11 to 5-21 refer to a four-pole, Y-connected synchronous generator rated at 470 kVA, 480 V, 60 Hz, and 0.85 PF lagging. Its armature resistance  $R_A$  is  $0.016 \Omega$ . The core losses of this generator at rated conditions are 7 kW, and the friction and windage losses are 8 kW. The open-circuit and short-circuit characteristics are shown in Figure P5-2.

- 5-11. (a) What is the saturated synchronous reactance of this generator at the rated conditions?
- (b) What is the unsaturated synchronous reactance of this generator?
- (c) Plot the saturated synchronous reactance of this generator as a function of load.
- 5-12. (a) What are the rated current and internal generated voltage of this generator?
- (b) What field current does this generator require to operate at the rated voltage, current, and power factor?
- 5-13. What is the voltage regulation of this generator at the rated current and power factor?
- 5-14. If this generator is operating at the rated conditions and the load is suddenly removed, what will the terminal voltage be?
- 5-15. What are the electrical losses in this generator at rated conditions?
- 5-16. If this machine is operating at rated conditions, what input torque must be applied to the shaft of this generator? Express your answer both in newton-meters and in pound-feet.
- 5-17. What is the torque angle  $\delta$  of this generator at rated conditions?
- 5-18. Assume that the generator field current is adjusted to supply 480 V under rated conditions. What is the static stability limit of this generator? (*Note:* You may ignore  $R_A$  to make this calculation easier.) How close is the full-load condition of this generator to the static stability limit?
- 5-19. Assume that the generator field current is adjusted to supply 480 V under rated conditions. Plot the power supplied by the generator as a function of the torque angle  $\delta$ . (*Note:* You may ignore  $R_A$  to make this calculation easier.)
- 5-20. Assume that the generator's field current is adjusted so that the generator supplies rated voltage at the rated load current and power factor. If the field current and the magnitude of the load current are held constant, how will the terminal voltage change as the load power factor varies from 0.85 PF lagging to 0.85 PF leading? Make a plot of the terminal voltage versus the impedance angle of the load being supplied by this generator.
- 5-21. Assume that the generator is connected to a 480-V infinite bus, and that its field current has been adjusted so that it is supplying rated power and power factor to the bus. You may ignore the armature resistance  $R_A$  when answering the following questions.
  - (a) What would happen to the real and reactive power supplied by this generator if the field flux is reduced by 5 percent?
  - (b) Plot the real power supplied by this generator as a function of the flux  $\phi$  as the flux is varied from 75 percent to 100 percent of the flux at rated conditions.

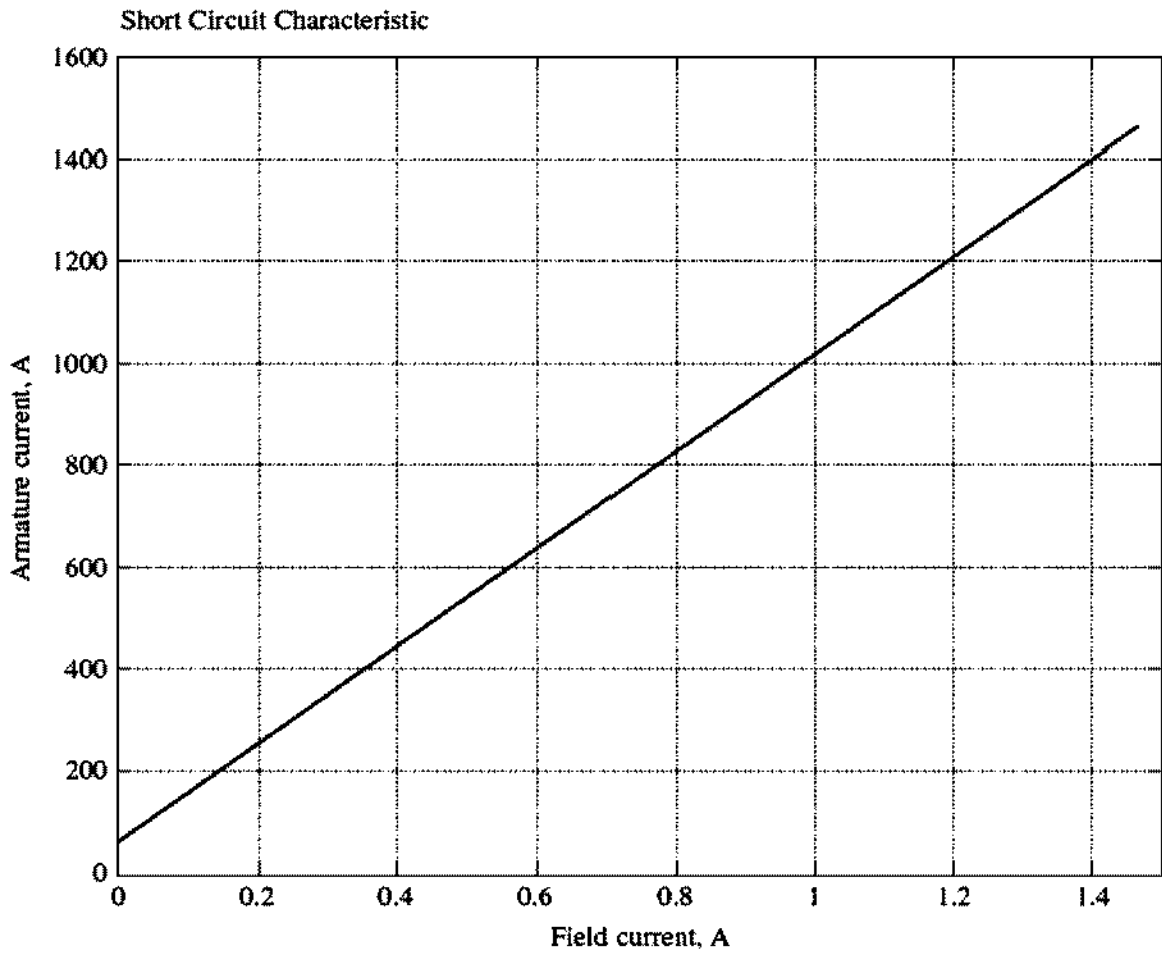
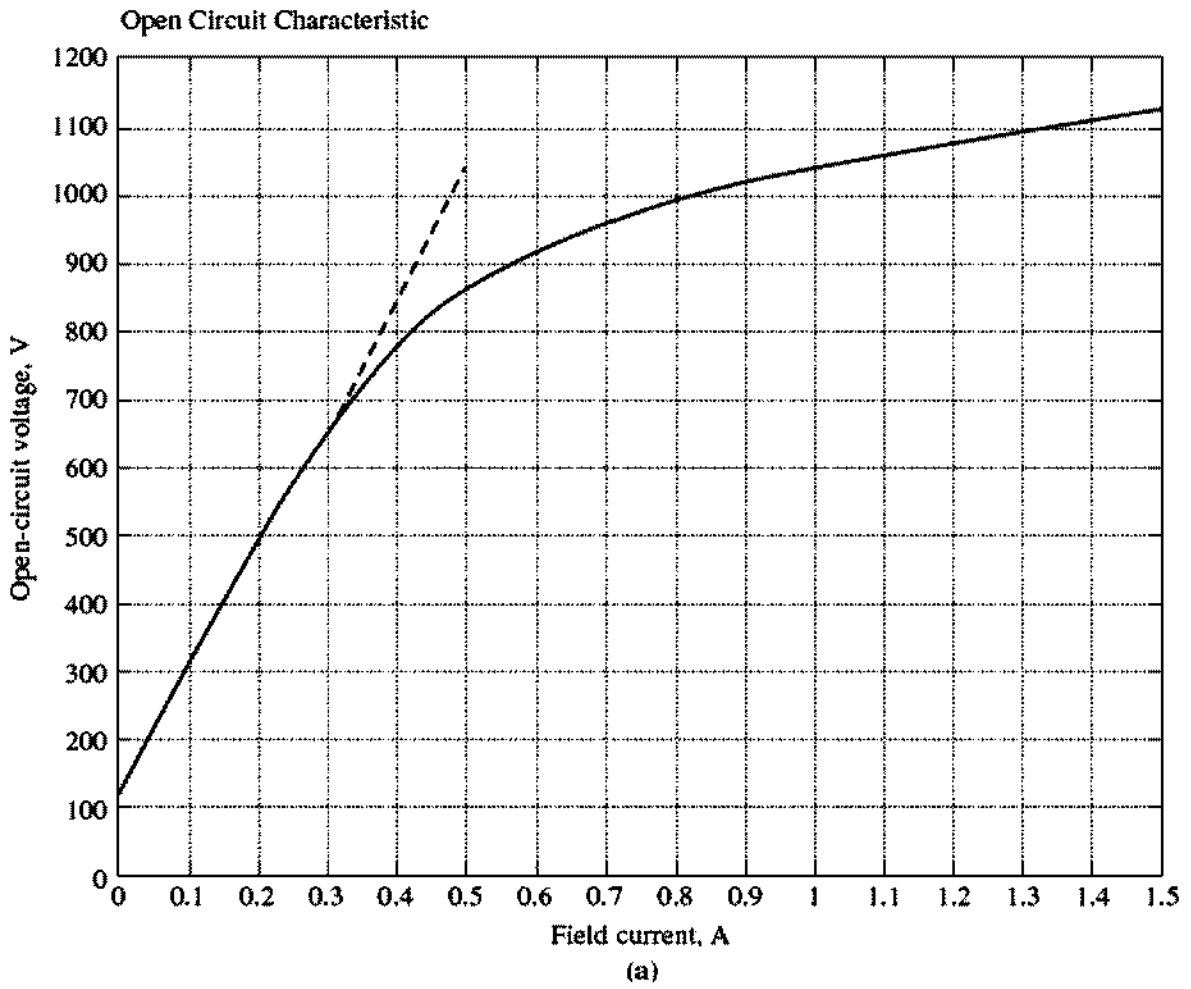

**FIGURE P5-2**  
 (a) Open-circuit characteristic curve for the generator in Problems 5-11 to 5-21. (b) Short-circuit characteristic curve for the generator in Problems 5-11 to 5-21.

- (c) Plot the reactive power supplied by this generator as a function of the flux  $\phi$  as the flux is varied from 75 percent to 100 percent of the flux at rated conditions.
- (d) Plot the line current supplied by this generator as a function of the flux  $\phi$  as the flux is varied from 75 percent to 100 percent of the flux at rated conditions.
- 5-22. A 100-MVA, 12.5-kV, 0.85-PF-lagging, 50-Hz, two-pole, Y-connected synchronous generator has a per-unit synchronous reactance of 1.1 and a per-unit armature resistance of 0.012.
- (a) What are its synchronous reactance and armature resistance in ohms?
- (b) What is the magnitude of the internal generated voltage  $E_A$  at the rated conditions? What is its torque angle  $\delta$  at these conditions?
- (c) Ignoring losses in this generator, what torque must be applied to its shaft by the prime mover at full load?
- 5-23. A three-phase Y-connected synchronous generator is rated 120 MVA, 13.2 kV, 0.8 PF lagging, and 60 Hz. Its synchronous reactance is  $0.9 \Omega$ , and its resistance may be ignored.
- (a) What is its voltage regulation?
- (b) What would the voltage and apparent power rating of this generator be if it were operated at 50 Hz with the same armature and field losses as it had at 60 Hz?
- (c) What would the voltage regulation of the generator be at 50 Hz?
- 5-24. Two identical 600-kVA, 480-V synchronous generators are connected in parallel to supply a load. The prime movers of the two generators happen to have different speed droop characteristics. When the field currents of the two generators are equal, one delivers 400 A at 0.9 PF lagging, while the other delivers 300 A at 0.72 PF lagging.
- (a) What are the real power and the reactive power supplied by each generator to the load?
- (b) What is the overall power factor of the load?
- (c) In what direction must the field current on each generator be adjusted in order for them to operate at the same power factor?
- 5-25. A generating station for a power system consists of four 120-MVA, 15-kV, 0.85-PF-lagging synchronous generators with identical speed droop characteristics operating in parallel. The governors on the generators' prime movers are adjusted to produce a 3-Hz drop from no load to full load. Three of these generators are each supplying a steady 75 MW at a frequency of 60 Hz, while the fourth generator (called the *swing generator*) handles all incremental load changes on the system while maintaining the system's frequency at 60 Hz.
- (a) At a given instant, the total system loads are 260 MW at a frequency of 60 Hz. What are the no-load frequencies of each of the system's generators?
- (b) If the system load rises to 290 MW and the generator's governor set points do not change, what will the new system frequency be?
- (c) To what frequency must the no-load frequency of the swing generator be adjusted in order to restore the system frequency to 60 Hz?
- (d) If the system is operating at the conditions described in part c, what would happen if the swing generator were tripped off the line (disconnected from the power line)?
- 5-26. Suppose that you were an engineer planning a new electric cogeneration facility for a plant with excess process steam. You have a choice of either two 10-MW turbine-generators or a single 20-MW turbine-generator. What would be the advantages and disadvantages of each choice?

- 5-27. A 25-MVA, three-phase, 13.8-kV, two-pole, 60-Hz Y-connected synchronous generator was tested by the open-circuit test, and its air-gap voltage was extrapolated with the following results:

Open-circuit test					
Field current, A	320	365	380	475	570
Line voltage, kV	13.0	13.8	14.1	15.2	16.0
Extrapolated air-gap voltage, kV	15.4	17.5	18.3	22.8	27.4

The short-circuit test was then performed with the following results:

Short-circuit test					
Field current, A	320	365	380	475	570
Armature current, A	1040	1190	1240	1550	1885

The armature resistance is  $0.24 \Omega$  per phase.

- Find the unsaturated synchronous reactance of this generator in ohms per phase and per unit.
  - Find the approximate saturated synchronous reactance  $X_s$  at a field current of 380 A. Express the answer both in ohms per phase and per unit.
  - Find the approximate saturated synchronous reactance at a field current of 475 A. Express the answer both in ohms per phase and in per-unit.
  - Find the short-circuit ratio for this generator.
- 5-28. A 20-MVA, 12.2-kV, 0.8-PF-lagging, Y-connected synchronous generator has a negligible armature resistance and a synchronous reactance of 1.1 per unit. The generator is connected in parallel with a 60-Hz, 12.2-kV infinite bus that is capable of supplying or consuming any amount of real or reactive power with no change in frequency or terminal voltage.
- What is the synchronous reactance of the generator in ohms?
  - What is the internal generated voltage  $E_A$  of this generator under rated conditions?
  - What is the armature current  $I_A$  in this machine at rated conditions?
  - Suppose that the generator is initially operating at rated conditions. If the internal generated voltage  $E_A$  is decreased by 5 percent, what will the new armature current  $I_A$  be?
  - Repeat part *d* for 10, 15, 20, and 25 percent reductions in  $E_A$ .
  - Plot the magnitude of the armature current  $I_A$  as a function of  $E_A$ . (You may wish to use MATLAB to create this plot.)

**REFERENCES**

1. Chaston, A. N. *Electric Machinery*. Reston, Va.: Reston Publishing, 1986.
2. Del Toro, V. *Electric Machines and Power Systems*. Englewood Cliffs, N.J.: Prentice-Hall, 1985.
3. Fitzgerald, A. E., and C. Kingsley, Jr. *Electric Machinery*. New York: McGraw-Hill, 1952.
4. Fitzgerald, A. E., C. Kingsley, Jr., and S. D. Umans. *Electric Machinery*, 5th ed., New York: McGraw-Hill, 1990.
5. Kosow, Irving L. *Electric Machinery and Transformers*. Englewood Cliffs, N.J.: Prentice-Hall, 1972.
6. Liwshitz-Garik, Michael, and Clyde Whipple. *Alternating-Current Machinery*. Princeton, N.J.: Van Nostrand, 1961.
7. McPherson, George. *An Introduction to Electrical Machines and Transformers*. New York: Wiley, 1981.
8. Slemon, G. R., and A. Straughen. *Electric Machines*. Reading, Mass.: Addison-Wesley, 1980.
9. Werninck, E. H. (ed.). *Electric Motor Handbook*. London: McGraw-Hill, 1978.